

**THE WEST AFRICAN EXAMINATIONS
COUNCIL, ACCRA**



**REGULATIONS, SCHEME AND
STRUCTURE OF EXAMINATION**

WITH

SAMPLE QUESTIONS

FOR

**BASIC EDUCATION CERTIFICATE
EXAMINATION**

(FROM 2024)

TABLE OF CONTENTS

| | |
|--|-----|
| REGULATIONS FOR THE BASIC EDUCATION | 2 |
| ARABIC | 14 |
| CAREER TECHNOLOGY | 19 |
| COMPUTING..... | 24 |
| CREATIVE ART AND DESIGN | 29 |
| ENGLISH LANGUAGE | 36 |
| FRENCH..... | 42 |
| Paper..... | 44 |
| Paper..... | 44 |
| GHANAIAAN LANGUAGE..... | 56 |
| MATHEMATICS | 119 |
| RELIGIOUS AND MORAL EDUCATION | 125 |
| SCIENCE..... | 130 |
| SOCIAL STUDIES..... | 136 |
| ADDRESSES OF OFFICES OF THE COUNCIL IN GHANA | 140 |

REGULATIONS FOR THE BASIC EDUCATION CERTIFICATE EXAMINATION (BECE)

INTRODUCTION

This booklet contains the Syllabus topics, Regulations, Schemes of Examination and Sample Questions for subjects of the Basic Education Certificate Examination that will be taken in Ghana with effect from 2024. The Regulations are meant to guide teachers and candidates preparing for the examination.

The Examination will be administered to school candidates in the third year of the Junior High School Education programme. The examination will test the extent to which candidates have covered the content of the teaching curricula approved by the Ministry of Education in Ghana. Candidates are expected to acquaint themselves thoroughly with the regulations since they form the basis for taking the examination.

The Basic Education Certificate Examination is made up of two components viz, the Continuous Assessment and External Examination. The Continuous Assessment and External Examination will be applicable to all candidates.

The Continuous Assessment forms 30% whilst the External Examination forms 70% of the total assessment.

A. GENERAL REGULATIONS FOR THE EXAMINATION

1. Entry for the Examination

- (a) The Basic Education Certificate Examination will be administered to all candidates in the third year of the Junior High School course and is open to all schools which are duly recognized by the Ministry of Education in Ghana.
- (b) Heads of School or their representatives are expected to register candidates based on official entry documents/guidelines provided by the West African Examinations Council.
- (c) Registration for the examination is done electronically through the Batch registration system. Photo Album generated from the Registration Software should be printed and submitted to the Council.
- (d) It is the responsibility of the Heads of School or their representatives to ensure that the Continuous Assessment scores of each candidate are duly entered
- (e) It is the responsibility of schools to check the correctness of entries made in respect of candidates' subjects/papers and to ensure that the appropriate fees are paid. The West African Examinations Council shall not take responsibility for any error, oversight or default made by Heads of school or their representatives.
- (f) The Council reserves the right to ensure that schools have adequate facilities for the conduct of the examination.

- (g) The Council reserves the right to refuse entries which do not satisfy the regulations of the examination. Entries which do not arrive before the closing date or which are not accompanied by the correct fees will be rejected for private schools.
- (h) The Council reserves the right to cancel any entry at any stage before the examination if it is found to be irregular.
- (i) The Council reserves the right to cancel the results of a candidate in subjects/papers for which he/she did not enter or for which he/she had no Continuous Assessment scores.
- (j) No candidate will be permitted to write the examination at any centre other than the one assigned.
- (k) The Council does not undertake to refund fees. When entries are refused or cancelled, any fees paid may be refunded in full but deductions may be made at the discretion of the Council to meet any administrative costs incurred.
- (l) The Entry Software will be made available to all schools on the Council's list that qualify to write the examination.
- (m) Qualified/Eligible candidates; The Basic Education Certificate Examination is available to students in their third/final year in Junior High Schools. It is illegal to register students who are
 - Not in your school or from other schools.
 - Not in form 3
 - Re-sitters

2. *Acceptance of Candidates for the Examination*

- (1) Candidates shall be presented through Schools recognized by the Ministry of Education of Ghana.
- (2) Heads of School or their representatives must ensure that the Continuous Assessment scores of all candidates entered for the examination are forwarded to the Council. The procedure for the completion and return of the Continuous Assessment scores to the Council will be communicated to the Schools at the time of entry.
- (3) Any candidate entered for the examination must be permitted to take the examination unless expelled by the Head of School for misconduct, prior to the commencement of, or during the examination. In circumstances where the expulsion of a candidate for misconduct is effected by the Head of School after the candidate has already taken some of the papers, the Council may, if the conditions for the award of a certificate are satisfied, duly award such a candidate a certificate. For the avoidance of doubt, the expelled candidate will no longer be eligible to take the remaining papers and the Council shall not make alternative arrangements for the candidate.

3. *General Arrangements*

- (1) The examination will be held once a year. The actual dates for each year will be communicated by a circular to all Schools through the Ghana Education Service. The examination time table will be made available along with the registration documents and guidelines.

(2) **Fees**

Payment of registration fees shall be made to designated Banks by the Council

(3) **Materials to be Provided**

Candidates will be provided pencils for objective papers. They are required to write their answers in **ink**;

Only blue ink may be used, and pencils may be used **only** for diagrams.

(4) **Infectious Diseases**

Candidates who have been exposed to any infectious diseases **cannot** write the examination at any centre unless they are quarantined.

4. Issue of Results and the Award of Certificates

- (1) The Council reserves the right to cancel the results of candidates if it is proved that they have been involved in irregularities before, during or after the examination. It also reserves the right to withhold certificates and to cancel certificates of candidates involved in any acts of malpractice.

The Council will not enter into correspondence about results with any candidate or their parents or guardians or any other persons claiming to act in loco parentis. All correspondence regarding such issues may only be dealt with directly between schools and the Council.

Results of candidates will be uploaded online. Results sheets and results slips will be sent to Heads of School after the release of results.

- (2) The award of a certificate is entirely within the discretion of the Council and the Council will not be liable to any candidate in respect of the withholding or cancellation of any certificate improperly obtained.
- (3) Certificates remain the property of the Council and legal proceedings will be instituted against any person who alters anything on them.
- (4) Examination scripts will be disposed of three months after the release of results

B. THE CONDUCT OF CANDIDATES IN THE EXAMINATION HALL**1. SUPERVISION OF THE EXAMINATION**

- (1) The examination shall be under the control of the Supervisor who shall be responsible to the Council for the proper conduct of the examination.
- (2) The Supervisor will be required to carry out the detailed instructions sent to him with reference to the conduct of the examination at the centre. These relate to the distribution of examination question papers to candidates, the collection of scripts at the end of each period, and their despatch to the Council in accordance with the

Council's directives and the maintenance of constant and effective supervision over the candidates

- (3) It is the duty of a Supervisor to report to the Council all cases of irregularity or misconduct in the examination. A candidate involved in such irregularity or misconduct must be allowed to continue the examination unless he/she interferes with the work of other candidates. Further action on such candidates will be taken by the Council in accordance with its rules and regulations.
- (4) A candidate whose examination work is affected by adverse circumstances should inform the Supervisor at the centre at which he/she takes the examination before, during, or immediately after the examination; in appropriate cases he/she must supply the Supervisor with a medical certificate, which should be forwarded to the Council.
- (5) The Council may, at any time, send a Special Supervisor to a school or centre to take control of the examination, or may send an Officer or Inspector to a school or centre during the examination to inspect the arrangements and to see that the examination is being conducted in strict accordance with the Regulations.

2. RULES AND REGULATIONS FOR DEALING WITH CASES OF IRREGULARITY IN THE COUNCIL'S EXAMINATIONS

DEFINITIONS

INSCRIPTION

This includes written or engraved, cut or carved letters, words, paragraphs, messages, etc. whether questions or answers to questions made and found on the skin, clothes or any surface.

MASS CHEATING

Where more than half of the candidates for a subject(s) at a centre are involved in collusion, this shall be regarded as mass cheating.

DE-RECOGNITION

This applies where the appropriate Committee of the Council is satisfied that a school involved in mass cheating cannot ensure the satisfactory conduct of the Council's examinations. This implies that the school authority can no longer organize or manage the school as a school centre, although the Council or its agent may use the physical facilities of the school for the purpose of the examinations. The school may be allowed to present its candidates as school candidates after fulfilling specified requirements, or move them to another centre for the conduct of the examination. However, the conduct of the whole examination (Objective, Practical and Essay) shall be the responsibility of the Council.

WITHDRAWAL OF RECOGNITION

Withdrawal of recognition implies that the school authority can no longer organise or manage the school as a centre, hence, the school will not be allowed to present its candidates as school candidates and the centre number will be withdrawn.

LEAKAGE

This occurs where candidates as well as the general public have access to examination question(s) before release from the Council's proper custody. It is the illegal filtration of the question(s) from the Council.

FOREKNOWLEDGE

This occurs where candidates and/or members of the general public have knowledge of the contents of examination question paper(s) after release from the Council's proper custody but before the scheduled time of examination.

EXPLANATORY NOTES

- A candidate is deemed to be *found with a material in the examination hall*, if the material is found:
 - (a) on any part of the candidate's body;
 - (b) in or on the desk/seat of the candidate.
- A school is deemed to have refused to grant examination official(s) *timely access into the school premises/examination hall* where it is found that the examination official(s) have identified themselves and they are not granted immediate entry thereafter, into the school premises for whatever reason.

THE RULES

1. BRINGING FOREIGN MATERIAL INTO EXAMINATION HALL

- (1) Where a candidate is found with a blank piece of paper, cribs, notes, textbooks, prepared material or any other printed material, in the examination hall (except mobile phone or any other electronic communication device), the following shall apply:
 - (a) where it is confirmed or there is evidence to show that the candidate is involved in examination malpractice in only one subject, the result of the subject involved, shall be withheld pending the outcome of investigation by the appropriate Committee of the Council.
 - (b) where it cannot be immediately confirmed or there is no evidence to show that the

candidate is involved in examination malpractice in only one subject, the entire results of the candidate shall be withheld pending the outcome of investigation by the appropriate Committee of the Council.

- (2) Where a candidate is found with a programmable calculator in the examination hall, the entire results of the candidate shall be withheld pending the outcome of investigation by the appropriate Committee of the Council.
- (3) Where a candidate is found in the examination hall to have inscription(s) on any part of his/her body or clothing, the candidate's entire results in the examination shall be withheld pending the outcome of investigation by the appropriate Committee of the Council.
- (4) Where a candidate is found with a mobile phone or any other electronic communication device in the examination hall, the entire results of the candidate shall be withheld pending the outcome of investigation by the appropriate Committee of the Council.

2. IRREGULAR ACTIVITIES INSIDE OR OUTSIDE THE EXAMINATION HALL

- (1) Where a candidate is apprehended for offence(s) such as those listed below inside or outside the examination hall, the candidate's entire results shall be withheld pending the outcome of investigation by the appropriate Committee of the Council:
 - (a) stealing, converting or misappropriating the scripts of other candidates.
 - (b) substituting worked scripts during or after the examination.
 - (c) submission of more than one worked script.
 - (d) possession of more than one question paper or answer booklet.
 - (e) seeking or receiving help from non-candidate(s) such as invigilator(s), supervisor(s), teacher(s) or other personalities before, during or after the examination.
- (2) Where the person giving the help is not a candidate for the examination in session, but a prospective candidate, he/she shall be barred from taking any examination conducted by the Council for 1 year and will also be reported to the appropriate authority for disciplinary action to be taken against him/her. In addition to the above action, the candidate's entire results shall be withheld pending the outcome of investigation by the appropriate Committee of the Council.
- (3) Where a candidate is apprehended for offence(s) such as those listed below inside or outside the examination hall, the candidate's entire results shall be withheld pending the outcome of investigation by the appropriate Committee of the Council:
 - (a) tearing part of the question paper or answer booklet during the examination.
 - (b) refusing to submit worked script to the Supervisor after the

examination.

- (c) starting to write an examination before commencement of work is officially announced OR continuing to write after official orders have been given for candidates to stop work.
- (d) other irregular activities including but not limited to causing noise or disturbances within the immediate precincts of the examination hall before, during or after the examination.

3. COLLUSION

- (1) Where a candidate is found during the examination passing notes for help from other candidate(s), receiving or giving assistance, talking with or colluding in any manner with another/other candidate(s), the entire results of the candidate(s) involved shall be withheld pending the outcome of investigation by the appropriate Committee of the Council.
- (2) Where cases of collusion are detected in script(s) and/or otherwise established in one paper, the entire results of the candidate(s) involved shall be withheld pending the outcome of investigation by the appropriate Committee of the Council.
- (3) Where a candidate is proved to have colluded with another/other candidate(s) in more than one paper/subject, the entire results of the candidate(s) involved shall be withheld pending the outcome of investigation by the appropriate Committee of the Council.

4. IMPERSONATION

- (1) Where a person is found impersonating a candidate, he/she shall be handed over to the Police for prosecution. The bona fide candidate, if apprehended, shall also be handed over to the Police for prosecution.
- (2) The entire results of the candidate being impersonated and those of the impersonator, if he/she is also a candidate for the examination, shall be withheld pending the outcome of investigation by the appropriate Committee of the Council.
- (3) Both the impersonator and the impersonated shall also be barred from taking any examination conducted by the Council for a period of not less than 2 years.

The Council also reserves the right to publish the names of persons so barred.

5. FOREKNOWLEDGE

- (1) Where a case of foreknowledge in a subject(s) is established at a centre, the entire results of the candidates offering the subject(s) involved at the centre shall be withheld pending the outcome of investigation by the appropriate Committee of the Council.
- (2) Where it is established that a case of foreknowledge occurred and any examination official(s), connived at, aided and/or encouraged the foreknowledge, the appropriate sanction(s) shall be meted out on all who are found culpable, by the appropriate Committee of the Council.

- (3) Where it is established that the school authorities condoned, connived at, and/or encouraged the case of foreknowledge, the school shall be de-recognised in accordance with Rule 7.

6. LEAKAGE

Where it is established that leakage has occurred and any examination official(s) connived at, aided and/or encouraged the leakage, the appropriate sanction(s) shall be meted out on all who are found culpable by the appropriate Committee of the Council.

7. MASS CHEATING

- (1) Where mass cheating in a subject(s) at a centre is established, the entire results of the candidates at the centre shall be withheld pending the outcome of investigation by the appropriate Committee of the Council.

- (2) Where mass cheating is established in more than one subject taken at a centre, the following shall apply:

(a) in the case of schools, a report shall be made to the Ministry of Education or the appropriate Board for disciplinary action to be taken against the person(s) responsible.

(b) the school shall be de-recognised for a period not less than 1 year.

(c) the school concerned may be required to pay penalty fees in addition to prescribed fees for the supervision and invigilation of the examination before the examination begins.

(d) in the case of public centres, the Council shall take appropriate action.

(e) notwithstanding (b) above, recognition may be restored up written assurance from the administering authority of the school that the necessary requirements have been satisfied. Such assurance shall contain details of measures taken to ensure the satisfactory conduct of the examination, and those which shall be put in place subject to acceptance by the Council.

Recognition, however, will only be restored after at least 1 year of de-recognition.

- (3) Where mass cheating is established in three (3) or more subjects taken at a centre, the schools/public centre's recognition shall be withdrawn.

Recognition of the school/public centre may be restored upon re-inspection and a written assurance that necessary measures have been put in place to forestall such

occurrence. The school after serving at least 5 years of the sanction, may begin a new process of recognition and a new centre number shall be given to the school.

8. INSULT/ASSAULT ON SUPERVISORS/INVIGILATORS/SCHOOL OFFICIALS/INSPECTORS

- (1) Where a candidate insults or assaults a supervisor/invigilator/school official/inspector in the lawful performance of his/her duties inside or outside the examination hall, or in any other way disturbs the conduct of the examination, the entire results of the candidate shall be withheld pending the outcome of investigation by the appropriate Committee of the Council. The candidate shall also be barred from taking any examination conducted by the Council for a period not less than 2 years. In addition, he/she may be handed over to the Police for prosecution.
- (2) Where a candidate brings into the examination hall or uses anything including firearms, chemical substances with intent to cause injury, temporary or permanent incapacity to any authorised person in the examination hall including other candidates, the entire results of the candidate shall be withheld pending the outcome of investigation by the appropriate Committee of the Council. In addition, the candidate shall be barred for a period of not less than 2 years from taking any examination conducted by the Council.
- (3) Where a school official(s) insult(s) or assault(s), incite(s)/instigate(s) the assault on an examination official(s) before, during or after the examination, such school(s) shall be de-recognised for a period not less than 2 years.
- (4) Where such assault in 8(3) causes injury (temporary or permanent) on the official(s), such school's recognition shall be withdrawn. The school shall be required to pay the cost of treatment of the injured examination official(s).
- (5) Without prejudice to Rule 8(3), where the Proprietor of the school is found to be involved in the assault, the recognition of the school shall be withdrawn.
- (6) Sanctions for Rules 8(1) - (5) above, shall not preclude legal action being taken against the offender(s) by the Council or affected individual(s).

9. CONTRAVENTION OF INSTRUCTIONS TO CANDIDATES

- (1) Where a candidate, in contravention of the instructions to candidates, writes with pencil instead of ink or shades with ink instead of pencil, the following shall apply:
 - (a) where it is confirmed that this is the only examination malpractice the candidate is involved in, the result of the subject involved, shall be withheld pending the outcome of investigation by the appropriate Committee of the Council.
 - (b) where it cannot be immediately confirmed that this is the only examination malpractice the candidate is involved in, the entire results of the candidate shall be withheld pending the outcome of investigation by the appropriate Committee of the Council.
- (2) Where a candidate fails to complete the cover page of his/her answer booklet as specified in the instructions, the following shall apply:
 - (a) where it is confirmed that this is the only examination malpractice the candidate is involved in, the result of the subject involved, shall be withheld pending the outcome of investigation by the appropriate Committee of the Council.
 - (b) where it cannot be immediately confirmed that this is the only examination malpractice the candidate is involved in, the entire results of the candidate shall be withheld pending the outcome of investigation by the appropriate Committee of the Council.

10. MULTIPLE REGISTRATIONS/REGISTRATION OF UNQUALIFIED CANDIDATES

- (1) Where a candidate is involved in multiple registrations for the same diet of examination and investigations reveal that the candidate sat the examination in more than one centre, the candidate's entire results shall be withheld pending the outcome of investigation by the appropriate Committee of the Council.
- (2) Where a Head of school(s) or its official(s) or representative(s) is/are found to have committed any of the offences listed below, before, during or after the conduct of the examination;
 - (a) Registration of non-school/unqualified candidate(s) for School Candidates' examinations;
 - (b) fabrication and/or falsification of continuous assessment scores for the affected candidate(s) in (a) above;

a report shall be made to the Ministry of Education or the appropriate Board for disciplinary action to be taken against the person(s) responsible and the school shall be de-recognised for a period not less than 1 year.

- (3) The non-school/unqualified candidate(s) who is/are found to be beneficiary (ies) of the school's breach as described above, shall have his/her/their entire results withheld pending the outcome of investigation by the appropriate Committee of the Council.

11. DESTRUCTION OF EXHIBITS

Where a candidate is apprehended in the examination hall or within its precincts, committing an offence or aiding another/other candidate(s) to commit an offence, and he/she proceeds to destroy the evidence of his/her offence, his/her entire results shall be withheld pending the outcome of investigation by the appropriate Committee of the Council.

12. POSTING LIVE QUESTIONS ON THE INTERNET

- (1) Where a candidate is found to have posted/received live questions/answers on the internet via social media, his/her entire results shall be withheld pending the outcome of investigation by the appropriate Committee of the Council.
- (2) Where it is found that the live questions were posted by any examination official(s), appropriate sanctions shall be meted out to whoever is found culpable. The matter shall also be reported to the Police for investigation and prosecution.

13. REFUSAL TO GRANT TIMELY ACCESS INTO THE SCHOOL PREMISES

Where a school is found to have refused to grant examination official(s) timely access into the school premises/examination hall, the following shall apply:

- (1) in the first instance, the school shall be warned.
- (2) where another report is received on the same school, the school shall be de-recognised for 2 years.

14. MISCONDUCT OF EXAMINATION OFFICIAL(S)

- (1) Where an examination official is found, inside or outside the examination hall with any material relevant to the examination being conducted and which may impugn the conduct of the examination, the examination official shall be handed over to the Police for investigation and prosecution. In addition, he/she shall be formally reported to his/her employer.
- (2) Where the school authorities offer bribe to examination officials before, during or after the period of the conduct of examinations, the school shall be de-recognised for 2 years and the relevant conditions in Rule 7 shall apply as appropriate.

15. NEW CASES

As new cases arise, which are not covered by the above rules, the appropriate Committee of the Council shall take necessary action.

16. REVIEW

These rules shall be subject to review as and when necessary.

C. SUBJECTS FOR THE EXAMINATION

The following subjects shall be available to candidates taking the Basic Education Certificate Examination from 2024:

1. Arabic
2. Career Technology
3. Computing
4. Creative Art and Design
5. English Language
6. French
7. Ghanaian Languages:
 - Dagaare
 - Dagbani
 - Dangme
 - Ewe
 - Fante
 - Ga
 - Gonja
 - Kasem
 - Nzema
 - Twi (Akuapem)
 - Twi (Asante)
8. Mathematics
9. Religious and Moral Education
10. Science
11. Social Studies

ARABIC

STRUCTURE AND SCHEME OF THE EXAMINATION

The examination will consist of three (3) Papers: Paper 1 (Objective), Paper 2 (Written Essay), and Paper 3 (Oral).

However, due to logistic constraints, the oral component (Paper 3) will be on hold for a while. It will be tested when the necessary logistics become available. Teachers are therefore advised to devote equal attention to the oral aspect of the syllabus.

1. PAPER 1 (OBJECTIVE)

The paper will consist of forty (40) objective questions covering lexis, structure and comprehension, all of which should be answered in 45 minutes for seventy (70) marks.

2. PAPER 2 (WRITTEN ESSAY)

Candidates will be required to answer one guided essay question out of three questions to be set. The questions may require picture description, letter writing, narration or description. The paper shall last for 1 hour and shall carry 30 marks.

3. WEIGHTING OF THE PAPER

(a) PAPER 1:

| | | | |
|---------------|--------------|-----------------|--------------------|
| Comprehension | 20 marks | | |
| Translation | 20 marks | | |
| Lexis | --- 10 marks | | |
| Grammar | 20 marks | | |
| Total | ----- | 70 marks | ----- (70%) |

(b) PAPER 2

| | | | |
|--------------|----------------|-----------------|--------------------|
| Composition | ----- 30 marks | | ----- (30%) |
| Total | ----- | 30 marks | ----- (30%) |

(c) Grand Total for Paper I & II: 100 marks (30%)

- (i) During the period that Paper 3 will not be administered, Papers 1 and 2 shall be weighted as follows:

| Paper | Total Marks | Scaling Factor | Total |
|---------------|-------------|----------------|-------|
| 1 (Objective) | 70 | 2.25 | 100 |
| 2 (Essay) | 30 | 1 | |

(ii) When Paper 3 is administered, the weighting should be as follows:

| Paper | Total Marks | Scaling Factor | Total |
|---------------|-------------|----------------|-------|
| 1 (Objective) | 70 | 2.25 | 100 |
| 2 (Essay) | 15 | 1 | |

SAMPLE QUESTIONS

PAPER 1 – COMPREHENSION

The paper consists of forty (40) objective questions which should be answered in 45 minutes for seventy (70) marks.

القراءة

(أ)

أرْمِيَاءُ تَلْمِيزٌ ذَكِيٌّ، تَحَدَّثَ يَوْمًا عَنْ أَسْرَتِهِ فَقَالَ: أَسْرَتِي صَغِيرَةٌ الْعِدَدِ لَكِنَّهَا سَعِيدَةٌ، فَأَبِي هُوَ الَّذِي يَتَعَبُ مِنْ أَجْلِنَا، وَأُمِّي هِيَ الَّتِي تَرَعَى الْبَيْتَ وَتَعْمَلُ عَلَيَّ رَاحَتَنَا، أَخَوَايَ الْكَبِيرَانِ مُعَاذٌ وَيُوسُفُ هُمَا اللَّذَانِ يُسَاعِدَانِي فِي فَهْمِ الدَّرُوسِ، كَمَا أَنَّ أُخْتِي مَيْمُونَةٌ. هِيَ الَّتِي تَقُومُ بِإِعْدَادِ الطَّعَامِ وَتَنْظِيفِ الْبَيْتِ، كَمَا تَحْضُرُ إِلَيَّ مَنْزِلَنَا عَمَّتِي الَّتِي تَعْمَلُ عَلَيَّ زِيَادَةَ الْخُبِّ بَيْنَ أَفْرَادِ أَسْرَتِنَا بِزِيَارَاتِهَا.

الأسئلة:

- أ. التلميذ الذكي في القطعة هو.....
- أ- معاذ ب- أرمياء ج- يوسف د- سعيد
- أ. الذي يتعب من أجل الأسرة هو
- أ- الأب ب- الخال ج- الأخ الأكبر د- العم
- أ. الذين يساعدون أرمياء في فهم دروسه هم
- أ- أبواه ب- أعمامه ج- أخواه د- أخواته
- أ. التي تقوم بإعداد الطعام هي
- أ- أخته ب- عمته ج- أخوه د- أبوه
5. العنوان المناسب للقطعة هو
- أ- جيرانتي ب- بيتي ج- إخواني د- أسرتي

(ب)

كَانَ الْخَلِيفَةُ عَمْرُ بْنُ الْخَطَّابِ يَسِيرُ فِي الْمَدِينَةِ وَمَعَهُ خَادِمُهُ، وَاللَّيْلُ مُظْلِمٌ وَالطَّرِيقُ خَالِيَةً مِنَ النَّاسِ، فَسَمِعَ صَوْتَ امْرَأَةٍ تَقُولُ لَا بِنْتَهَا : قُومِي يَا ابْنَتِي وَضْعِي مَاءً فِي اللَّبَنِ وَاسْتَعْدِي لِبَيْعِهِ فِي الصَّبَاحِ. فَأَجَابَتْ الْبِنْتُ: إِنَّ الْخَلِيفَةَ مَنَعَنَا مِنْ عِشِّ اللَّبَنِ بِأَمَاءٍ. قَالَتْ أُمُّ: الْخَلِيفَةُ غَائِبٌ فَهَلْ يَرَانَا؟ أَوْ هَلْ يَرَانَا أَحَدٌ؟ قَالَتْ الْبِنْتُ: لَا يَرَانَا أَحَدٌ مِنَ النَّاسِ يَا أُمَاهُ وَلَكِنَّ اللَّهَ يَرَانَا. أَعْجَبَ أَمِيرُ الْمُؤْمِنِينَ بِكَلَامِ الْفَتَاةِ وَبِحُسْنِ أَخْلَاقِهَا، ثُمَّ قَالَ لِخَادِمِهِ: الْفَتَاةُ طَيِّبَةٌ وَسَوْفَ أَرْوِّجُهَا لَوْلَدِي عَاصِمِ.

6. الذي يسير في المدينة كما في القطعة هو

- أ- الأمير ب- الخادم ج- الخليفة د- السلطان
7. كلمة الطريق مرادفها
- أ- المعبر ب- الشارع ج- الجسر د- المنفذ
8. العنوان المناسب للقطعة هو : بائعة.....
- أ- الزيت ب- السكر ج- اللبن د- العسل
9. الذي قال له الخليفة: الفتاة طيبة، هو
- أ- الخادم ب- الخليفة ج- عاصم د- الملك
10. القائلة: " إن الخليفة لا يرانا ولكن الله يراها" هي.....
- أ- المرأة ب- البنت ج- الأم د- الخامة

GRAMMAR

النحو

11. أنت تلميذ مجتهد. كلمة (أنت) ضمير
 أ- مخاطبة ب- غائب ج- مخاطب د- غائبة
12. جاء محمد
 أ- مبكراً ب- مبكراً ج- مبكراً د- المبكر
13. متى كتبتِ الدرس يا فاطمة. الفعل المضارع ل(كتبت) هو
 أ- تكتب ب- تكتبان ج- تكتبين د- تكتبين
14. (على) من حروف
 أ- النفي ب- الجر ج- النصب د- الجزم
15. أنا قرأتُ كتاباً
 أ- جديداً ب- جديدةً ج- جديداً د- جديد
16. مكث الضيف عندنا
 أ- يوماً ب- يومٍ ج- اليوم د- يوم
17. وصلت زينب
 أ- ليلٍ ب- ليلٍ ج- الليل د- ليلاً
18. رأيت كانتا معنا أمس.
 أ- اللذين ب- اللاتي ج- التي د- اللتين
19. مثني لكلمة (هذه) هو
 أ- هذان ب- هتان ج- هذا د- هؤلاء
20. من يزرع
 أ- يقطع ب- يقطع ج- يحصد د- يخرج

SUBJECT: TRANSLATION

الترجمة

الترجمة العربية إلى الإنجليزية ومن الإنجليزية إلى العربية

TRANSLATION: ARABIC INTO ENGLISH AND ENGLISH INTO ARABIC:

اختر من الكلمة الإنجليزية المفردة أو المجموعة المتعددة من أ إلى د ما هي أتم تَرْجَمَةُ للكلمة العربية المفردة أو المجموعة التي تحتها خطٌ مِنْ كُلِّ واحدٍ من الجمل العربية الآتية.

From the list of the English words or group of words lettered A to D below each of the following Arabic sentences, choose the one that best translates the underlined Arabic words or group of words.

(21) يَطْلُبُ مِنْ صَدِيقِهِ قَلَمًا

A. for B. in C. on D. from

(22) لَا تَلْعَبُ أَمَامَ الْمُعَلِّمِ

A. ahead of B. in front of C. on top of D. faraway from

(23) أَخْبَرَنِي رَجُلٌ عَنِ الْكِتَابِ

A. about B. from C. off D. in

(24) هَذَا مَنْزِلُ الْمُدِيرِ

A. building B. room C. office D. house

(25) يَذَاكِرُ الطَّالِبُ دُرُوسَهُ دَائِمًا

A. sometimes B. always C. daily D. promptly

اخْتَرِ مِنَ الْكَلِمَةِ الْعَرَبِيَّةِ الْمُفْرَدَةِ أَوْ الْمَجْمُوعَةِ الْمُتَعَدِّدَةِ مِنْ أ إِلَى د مَا هِيَ أْتَمَّ تَرْجَمَةَ لِلْكَلِمَةِ الْإِنْجِلِيزِيَّةِ الْمُفْرَدَةِ أَوْ الْمَجْمُوعَةِ الَّتِي تَحْتَهَا خَطٌّ مِنْ كُلِّ وَاحِدٍ مِنَ الْجُمَلِ الْإِنْجِلِيزِيَّةِ الْآتِيَةِ.

From the list of the Arabic words or group of words lettered A to D below each of the following English sentences, choose the one that best translates the underlined English words or group of words.

26. I saw him sleeping.

أ. راقدا ب. ساجدا ج. نائما د. ناظرا

27. He rushed into the kitchen.

أ. العُرْفَةُ ب. المَطْبِخُ ج. الفندق د. المطعم

28. I am happy.

أ. سعيد ب. جانع ج. سليم د. حزين

29. The books are under the table.

أ. فوق ب. وراء ج. على د. تحت

39. My father loves me,

أ. يربى ب. يادب ج. يحب د. يرعى

40. I am a student at the University.

أ. جامعة ب. معهد ج. مدرسة د. كلية

PAPER 2 READING – ORAL

المطالعة - الشفوي

تُنْدِي يُحِبُّ الرِّيَاضَةَ الْبَدَنِيَّةَ، وَيَهْوِي كُرَةَ الْقَدَمِ، وَلِتَعْلَفَ بِهَا كَانَ يَجْمَعُ رِفَاقَهُ وَيَلْعَبُونَ بِهَا فِي الطَّرِيقِ. وَذَاتَ يَوْمٍ حَمِيَ اللَّعِبُ، فَطَارَتْ مِنْهُمُ الْكُرَةُ، وَأَصَابَتْ طِفْلاً مَارًّا، فَرَمَتْهُ عَلَى الْأَرْضِ، فَوَقَعَ يَصْرُخُ وَيَبْكِي. وَتَجَمَّعَ النَّاسُ فَأَخَذُوا بِيَدِ الطِّفْلِ، وَنَفَّضُوا الْعُبَارَ عَنْ تَوْبِهِ، وَمَا زَالُوا بِهِ حَتَّى هَذَا، وَثَارُوا بِتُنْدِي وَرِفَاقِهِ، فَمَشَوْا وَتَرَكَوا الطَّرِيقَ. لَمْ يَتْرِكْ تُنْدِي اللَّعِبَ بِالْكَرَةِ فِي الطَّرِيقِ وَلَمْ يَتْرِكْهُ رِفَاقَهُ، وَفِي مَرَّةٍ قَذَفَ تُنْدِي الْكُرَةَ فَصَدَمَتْ رُجَاجَ سَيَّارَةٍ، فَحَطَّمَتْهُ، وَتَنَاشَرَ عَلَى الْأَرْضِ. وَوَقَّفَ صَاحِبُ السَّيَّارَةِ، وَأَصَرَ أَنْ يُقَدِّمَهُمْ إِلَى الشَّرْطَةِ.

وَفِي هَذَا الْوَقْتِ حَضَرَ وَالِدُ تُنْدِي، وَاسْتَعَدَّ لِتَرْكِيبِ رُجَاجِ السَّيَّارَةِ، فَتَسَامَحَ الرَّجُلُ، وَمَضَى بِسَيَّارَتِهِ، وَمِنْذَ حِينَ وَأَقْلَعَ تُنْدِي وَرِفَاقَهُ عَنِ اللَّعِبِ بِالْكَرَةِ فِي الطَّرِيقِ.

CAREER TECHNOLOGY

STRUCTURE AND SCHEME OF THE EXAMINATION

There shall be two Papers, Paper 1 and Paper 2 all of which must be taken. Papers 1 and 2 will be a composite paper taken at one sitting for 2 hours, 5 minutes.

1. PAPER 1 (OBJECTIVE)

This will consist of forty (40) multiple choice questions to be answered in fifty (50) minutes for forty (40) marks.

2. PAPER 2

This will consist of two parts (Part A and Part B) and will last for 1 hour 15 minutes.

Part A will comprise three (3) questions. Candidates will be expected to answer two (2) questions, of which question 1 (test of practical) is compulsory, for 15 marks each.

Part B will comprise three (3) questions. Candidates will be expected to answer two (2) questions, of which question 4 (test of practical) is compulsory, for 15 marks each.

3. WEIGHTING OF THE PAPER

| PAPER | MARKS | SCALING FACTOR | TOTAL MARKS |
|--------------|--------------|-----------------------|--------------------|
| 1 | 40 | 1.0 | 40 |
| 2 | 60 | 1.0 | 60 |
| TOTAL | | | 100 |

SAMPLE QUESTIONS**PAPER 1 (OBJECTIVE)****50 Minutes**

Candidates are expected to answer 40 question in this paper

Each question is followed by **four** options lettered A to D. Find the **correct** option for **each** question and shade in **pencil** on your answer sheet the answer space which bears the same letter as the option you have chosen. Give only **one** answer to **each** question.

1. Musa advised her mother to select a polyester fabric for curtains in their home. The main reason for his choice is that, it
 - A. can be obtained in different colours.
 - B. can withstand frequent washing.
 - C. is light in weight.
 - D. soft to touch.

2. A suitable edge finish for a kitchen apron is
 - A. crocheting.
 - B. facing.
 - C. fringing.
 - D. lacing.

3. The most appropriate meal for a child suffering from kwashiorkor is
 - A. beans soup and boiled rice.
 - B. fish palava sauce and mashed yam.
 - C. shito and banku.
 - D. pepper sauce and boiled cassava.

4. Which of the following foods is prepared using dry method of cooking?
 - A. Bread
 - B. Kenkey
 - C. Kokonte
 - D. Koose

5. The French curve is a tool used in dress making for
 - A. cutting fabrics.
 - B. shaping hemline.
 - C. shaping neck lines and arm hole.
 - D. taking body measurement.

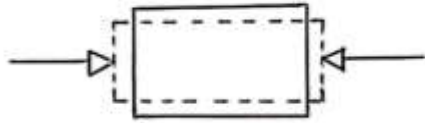

Figure 1

6. The type of force acting on the object shown in Figure 1 is
- bending force.
 - compression force.
 - shear force.
 - tension force.
7. In perspective drawing, the point at which receding parallel lines appear to meet is known as
- focal point.
 - horizon line.
 - vanishing point.
 - vertical line.
8. The cutting edge of a cold chisel is ground at
- 30° .
 - 45° .
 - 60° .
 - 90° .

Figure 2 shows the process of laying a wall. Use it to answer questions 9 and 10.

Figure 2 shows the process of laying a wall. Use it to answer questions 9 and 10.

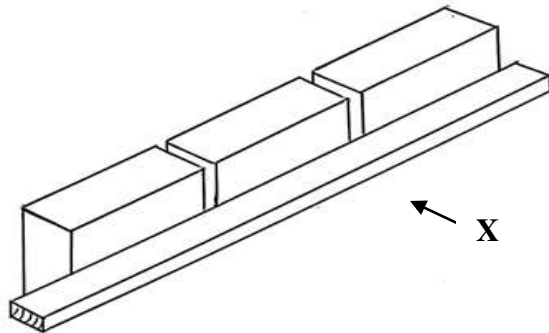

Figure 2

9. The process shows blocks being
- aligned.
 - gauged.
 - levelled.
 - plumbed.

10. The tool labelled **X** is a
- A. builder's square.
 - B. gauge rod.
 - C. spirit level.
 - D. straight edge.

PAPER 2**PART A**

Answer two questions only from this part. Question 1 (Compulsory) and any other one.

1. Describe how to prepare pineapple drink and Queen's cakes using the basic recipe.

[15 Marks]

2. (a) Describe one way of maintaining personal hygiene.
 (b) Explain food hygiene.
 (c) Outline one measure to ensure food safety.
 (d) Suggest two measures to be taken to prevent poor environmental conditions.

[15 Marks]

PART B

Answer two questions only from this part. Question 3 (Compulsory) and any other one.

3. Illustrate the stages involved in preparing a T- halving joint as shown in Figure 2 from the piece of wood shown in Figure 1.

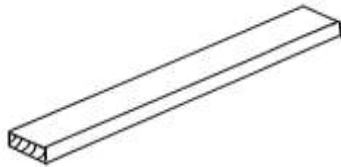

Figure 1

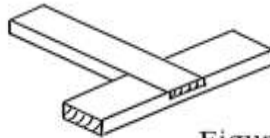

Figure 2

[15 Marks]

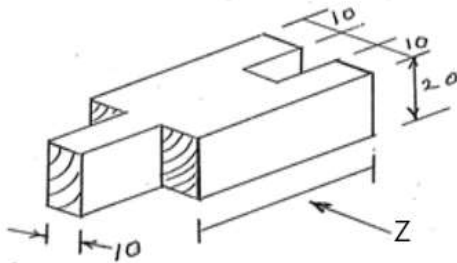

Figure 3

4. Draw full size in the First Angle Orthographic Projection:
 (a) the front elevation in the direction of arrow Z;
 (b) the plan.

[15 Marks]

COMPUTING

STRUCTURE AND SCHEME OF THE EXAMINATION

The examination will consist of two papers for a total duration of 2 hours. Paper 2 which comes first will be (Essay) and Paper 1 which follows will be (Objective).

1. PAPER 1 (OBJECTIVE)

The paper will consist of 40 compulsory objective questions and will last for 45 minutes. This will carry 40 marks.

2. PAPER 2 (ESSAY)

The paper will consist of two sections: A and B.

Section A will be a compulsory question for 24 marks and Section B will have 4 questions out of which candidates will answer any 3 for 12 marks each. The Paper will last 1 hour 15 minutes and will carry 60 marks.

NB: Candidates are expected to answer **only four** questions in all. Any candidate, who contravenes this instruction, would have only the first four answers marked leaving those in excess unmarked.

3. WEIGHTING OF THE PAPER

| Paper | Marks | Scaling factor | Total marks |
|---------------|-------|----------------|-------------|
| 1 (Objective) | 40 | 1 | 100 |
| 2 (Essay) | 60 | 1 | |

SAMPLE QUESTIONS
PAPER 1 (OBJECTIVE)

Candidates are expected to answer 40 questions on this paper.

*Each question is followed by **four** options lettered A to D. Find the **correct** option for **each** question and shade in **pencil** on your answer sheet the answer space which bears the same letter as the option you have chosen. Give only **one** answer to **each** question.*

1. Which program icon on the desktop leads to the disk drives?
 - A. Internet Explorer
 - B. My Computer
 - C. My Document
 - D. My Network Places

2. The Fourth Generation of computers is associated with
 - A. vacuum tubes.
 - B. semi-conductors.
 - C. transistors.
 - D. microprocessor.

3. To underline selected text in a Word document, use the keys
 - A. Ctrl + U
 - B. Shift + U
 - C. Alt + U
 - D. Del + U

4. The default MS PowerPoint layout is
 - A. section header.
 - B. title only.
 - C. two content.
 - D. title slide.

5. Which of the following measures is used to evaluate a webpage to ensure how true the information acquired is?
 - A. Currency
 - B. Content
 - C. Credible
 - D. Accuracy

6. A bit that is turned OFF represents
 - A. 1
 - B. -1
 - C. 0
 - D. ± 1

7. The step-by-step approach used in solving a specific problem is
 - A. sequencing.
 - B. selection.
 - C. algorithm.
 - D. iteration.

8. Convert 15_{ten} to a binary
 - A. 1111_2
 - B. 1110_2
 - C. 1011_2
 - D. 1101_2

9. The robotic component that allows the robot to interact with its environment such as movement and manipulation are
 - A. sensors.
 - B. actuators.
 - C. power source.
 - D. control systems.

10. In querying an expert system, the IF-THEN control structure
 - A. provides information on the use of the system.
 - B. specifies the reason for querying the system.
 - C. provides information about the user of the system.
 - D. specifies a condition and an action to be taken.

PAPER 2 (ESSAY)

*This paper is in **two** sections. **A** and **B**. Candidates are expected to answer *Question 1* in section **A** and any other **three** questions in Section **B***

SECTION A

[24 marks]

Answer Question 1

[**Compulsory**]

- The Head of your school presented the program shown in Fig. 1 to the school's Programming Club. The program creates usernames for students in the school. Members of the Club were then tasked to discuss and answer the questions that follow:

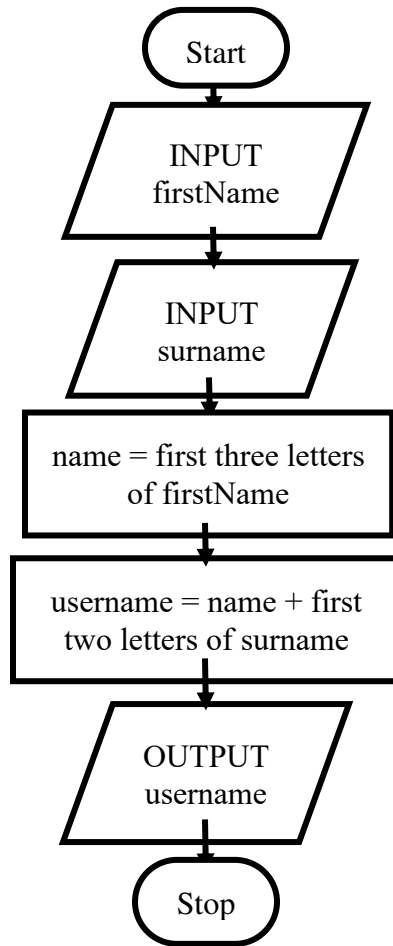

Fig. 1

Using the process in Fig 1, Kojo Baah's username would be KojBa.

- Write the name of Fig 1:

[2 marks]

- Using the process in Fig 1, create the username for Patience Mensah.

.....[2 marks]

- (c) Draw the symbol that represents the processing stage of the program
 [2 marks]

Fig 1 is updated to create usernames as follows: username is the last 3 letters of surname and the first 2 letters of first name.

- (d) What will be the username for a student called Mark Elolo using the updated process?
 [4 marks]

- (e) Write an algorithm for the updated process in (d).

[14 marks]

SECTION B

[36 marks]

*Candidates are expected to answer **three** questions **only** from this section.*

- 2. (a) Discuss **one** features each of the fourth generation computers in terms of:
 - (i) cost:
 - (ii) processor:

[6 marks]

- (b) Describe **three** features of the computer mouse.
 - (i)
 - (ii)
 - (iii)

[6 marks]

- 3. (a) Describe the best way to resize a picture in order to avoid distorting its aspect ratio.

[3 marks]

- (b) Differentiate between the *Save* and the *Save As* commands. Give one example each in both cases

[6 marks]

- (c) Kojo Talata designed a brochure which contains texts and images. He is finding it difficult to write the texts around the images as the desktop publishing application is not allowing that. What tool will be applicable to achieve the task?

[3 marks]

CREATIVE ART AND DESIGN

STRUCTURE AND SCHEME OF THE EXAMINATION

The examination will consist of two papers - that is Paper 1 and Paper 2. It should be noted that both papers shall be taken at a sitting within 2 hour and 5 minutes.

1. PAPER 1 (OBJECTIVE)

It comprises of forty objective questions to be answered within 45 minutes for 40 marks.

2. PAPER 2 (ESSAY)

The duration for this paper is 1hour, 20 minutes and it consists of 3 Sections; that is A, B and C. Candidates are expected to answer (4) questions. Details of the Sections are as follows:

(a) Section A (Visual Art)

This section consists of three questions: Question 1 would be on *Design* and it is compulsory. Questions 2 and 3 would be centred on other *Art strands*. The candidates are expected to answer any one in addition to question 1.

Due to the practical nature of the subject, candidates are required to come to the examination hall with at least:

- Pencils
- Colour pencils/ water-colour/crayons
- Eraser and
- Ruler.

NB: Whenever there is the need to use special tools, materials and found objects the schools would be given advanced notification.

(b) Section B (Music)

This section would be made up of two questions and candidates are expected to answer only one question.

(c) Section C (Dance and Drama)

Section C would consist of two questions and candidates are expected to answer only one of them.

NB: Candidates are expected to answer **only four** questions in all. Any candidate, who contravenes this instruction, would have only the first four answers marked leaving those in excess unmarked.

3. WEIGHTING OF THE PAPER

| PAPERS | NO. OF ITEMS TO BE ANSWERED | MARKS | SCALING FACTOR | TOTAL MARKS |
|-------------------|--|--------------|---------------------------|------------------------|
| 1 (Objectives) | 40 | 40 | 1.0 | 100 |
| 2 (Essay) | 4 | 60 | 1.0 | |

SAMPLE QUESTIONS**PAPER 1 (OBJECTIVES)**

4. Select a set of elements of design from the options below.
 - A. Shape, colour, unity and dot.
 - B. Harmony, unity, colour and shape
 - C. Line, dots, texture and colour
 - D. Line, harmony, texture and dot

5. Identify an element of design in nature that shows line.
 - A. Shoe lace
 - B. Cable
 - C. Apple
 - D. Veins on leaves

6. Which principle is used to show size relationships of one part to other parts of an object?
 - A. Pattern
 - B. Proportion
 - C. Contrast
 - D. Harmony

7. Construction and assemblage deals with recycling of found objects such as
 - A. stables.
 - B. scraps.
 - C. mobiles.
 - D. origami.

8. Which part of a poster helps the public to understand the message better?
 - A. Theme
 - B. Text
 - C. Layout
 - D. Illustration

9. Amabi intends to cast a statute with chip to be mounted in front of the school's library. Identify the most suitable material she can use for making the mould.
 - A. plaster of paris.
 - B. wax.
 - C. fine sand.
 - D. cement.

10. Elements of dance and drama are the building blocks for
- A. choreography and play writing.
 - B. instrumentation and choreography.
 - C. play writing and Instrumentation.
 - D. Composing and choreography.
11. In Dance and Drama, gestures and facial expressions are used to communicate
- A. verbally.
 - B. through telephone.
 - C. through whispering.
 - D. non-verbally.
12. Afua Abasa is to Nnwonkoro as E.T Mensah is to
- A. Hip life
 - B. Kete
 - C. Highlife
 - D. Adowa
13. In reference to John Curwen's hand signs, what is the Solfege name for the technique below?



- A. Do
- B. RE
- C. MI
- D. FA

PAPER 2 (ESSAY)

*This paper consist of **three** sections: **A, B** and **C**. Section **A** has **three** questions, answer question **1** any other question. Section **B** and **C** has **two** questions **each**, answer **one** question from **each** section.*

SECTION A (VISUAL ART)

*Section **A** has **three** questions, answer question **1** and any other question*

1. DESIGN (Compulsory)

Create a random **line doodle pattern** and **hatch** the various sections with colour pencil. The pattern should be in **primary colours**.

[15 marks]

2. (a) The passage below is a description of how marbling is done. Fill in the blank spaces with the words provided to make the passage complete and meaningful.

(paper, transferred, water, decorative, design, controlled, float, gently, designer, paint)

Marbling is aprocess, which can either be or uncontrolled. Generally the use a sheet of, paint, kerosene and a bowl of water. The kerosene is added to the bowl of water. The is sprinkled on the in the bowl. The kerosene makes the paint in the water to create a A plain sheet is lowered on top of the design. When lifted, the design isonto the sheet.

[10 marks]

- (b) Japan Motors Company Limited is organizing a school-based competition on a prototype new car, intended to be manufactured in 2030.

- (i) Identify **one** technique you can use in carrying out the project. [1 mark]
 (ii) Indicate **two** materials needed in carrying out the project. [2 marks]
 (iii) List **two** tools involved in achieving the technique in b (i). [2 marks]

SECTION B (MUSIC)

*Answer only **one** question from this section.*

3. (a) On the staff below, construct the scale of *F major* ascending using the *treble clef* without key signature.



[6 marks]

- (b) On the staff below, construct the scale of G major descending using the bass clef with key signature.



[6 marks]

- (c) Construct the following *triads* in *solfa*.

- i. I
- ii. IV
- iii. V

[3 mark]

4. (a) State the meaning of the following Italian terms:

- i. Presto
- ii. Allegro
- iii. Piano

[3 marks]

- (b) Explain the following number positions as used in music

- i. The top number of the time signature.
- ii. The bottom number of a time signature.

[4 marks]

- (c) Indicate the type of *notes* in the following time signatures:

- i. 4/4 time.
- ii. 2/2 time.

[2 marks]

- (d) Using the table below, put the listed musicians under *Art*, *Popular* and *Traditional/Indigenous*

(*Agya Koo Nimo, J.H.K Nketia, E.T Mensah*)

| Art | Popular | Traditional/Indigenous |
|-----|---------|------------------------|
| | | |

[3 marks]

- (e) Identify **one** song from the following composers which talks about issues in the Ghanaian community.

- i. Kofi Kinnata
- ii. George Jarrah
- iii. Osei Boateng

[3 marks]

SECTION C (DANCE AND DRAMA)

*Answer only **one** question from this section.*

5. (a) Using appropriate examples, describe how the following elements are used in contemporary dance piece:
- i) Body;
 - ii) Space;
 - iii) Energy.
- [6 marks]**
- (b) Explain **any one** importance of event planning and management in Dance and Drama production.
- [3 marks]**
- (c) Explain any **two** roles of storytelling in Ghanaian culture.
- [6 marks]**
6. (a) Explain the role of any **two** of the following elements in dance and drama.
- (i) Props
 - (ii) Costume
 - (iii) Lighting.
- [6 marks]**
- (b) Identify any **four** roles of dance and drama in Ghanaian culture.
- [4 marks]**
- (c) Your school is planning to organize an End of Year Drama Festival. You have been chosen to lead in planning the event for the school. Describe briefly the processes involved in planning a good event.
- [5 marks]**

ENGLISH LANGUAGE

STRUCTURE AND SCHEME OF THE EXAMINATION

There will be two papers, Paper 1 and Paper 2, both of which will be taken at a sitting.

1. PAPER 1 (OBJECTIVE)

This shall be an objective test comprising two parts: Grammar Usage and Oral Language. Grammar Usage shall consist of 35 questions while the Oral Language Component shall have 5 questions. The 40 questions will be answered in 50 minutes for 40 marks.

2. PAPER 2 (ESSAY)

This paper shall consist of three parts: Part A-Writing, Part B- Reading (Comprehension and Summarising) and Part C-Literature

There will be three questions in Part A and candidates will be expected to answer one. In Part B, there will be one passage and candidates will be required to answer all the questions on it. Part C shall comprise 10 questions, all of which must be answered.

The paper will last 1 hour, ten minutes and will carry 60 marks.

3. WEIGHTING OF THE PAPER

| Paper | Items | Marks | Scaling Factor | Total |
|-------------------------------|-------|-------|----------------|-------|
| 1 (Objective) | | 40 | 1 | 100 |
| Grammar Usage | 35 | | | |
| Oral Language | 5 | | | |
| 2 (Essay) | | 60 | 1 | |
| Comprehension and Summarising | 1 | | | |
| Writing | 1 | | | |
| Literature | 1 | | | |

SAMPLE QUESTIONS
PAPER 1 (OBJECTIVE)
PART A – GRAMMAR USAGE

SECTION A

*From the letters A to D, choose the one which **most suitably completes** each sentence.*

1. She ought to be here by now, ...?
 - A. Mustn't she
 - B. Isn't it
 - C. Isn't she
 - D. Oughtn't she

SECTION B

*Choose from letters A to D, the one which is **nearest in meaning** to the **underlined** word in **each** sentence.*

2. Dr. Senoo made a tremendous effort to get the brothers reconciled.
 - A. Manifold
 - B. Great
 - C. Confident
 - D. Massive

SECTION C

*In **each** of the following sentences a group of words has been underlined. Choose from the alternatives lettered A to D that **best explains** the underlined group of words.*

3. Any journalist, worth their salt would choose a more interesting headline. This means that
 - A. a competent journalist would
 - B. a salt loving journalist would
 - C. a well-known journalist would
 - D. a fearless journalist would

SECTION D

*From the list of words lettered A to D, choose the one that is **most nearly opposite in meaning** to the word underlined in each sentence.*

4. When Kwansema saw Amissah scurry out of the kitchen with a covered bowl, she became suspicious.
 - A. crawl
 - B. rush
 - C. tip-toe
 - D. walk

SECTION E

*In the following passage the numbered gaps indicate missing words. Against **each** number in the list below the passage, **four** choices are offered in columns lettered **A** to **D**. For **each** numbered gap, choose from the options provided, the word that is **most** suitable.*

Mining is classified under the **-5-** sector of the economy. Ghana, formerly called the Gold Coast, is a country rich in mineral **-6-**. Besides the more well-known ones like gold, bauxite, manganese and copper, **-7-** is the latest mineral discovered in commercial quantities. Discussions are being held to consider **-8-** it for export.

| | A | B | C | D |
|----|------------|-------------|-------------|---------------|
| 5. | productive | quarrying | extractive | manufacturing |
| 6. | vault | deposits | credit | stores |
| 7. | lithium | petroleum | crude oil | ore |
| 8. | recovering | discovering | prospecting | exploring |

PART B – ORAL LANGUAGE**SECTION F**

*From the list A to D, choose the one which has the **same vowel sound** as the word underlined in the sentences below.*

9. The whole area was submerged.

- A. go
- B. new
- C. bill
- D. bale

*From the list A to D, choose the one which has the **same consonant sound** as the word underlined in the sentences below.*

10. The blade of the sword is very sharp indeed!

- A. grade
- B. flood
- C. breed
- D. glade

PAPER 2
PART A
WRITING
[30 marks]

*Answer **one** question **only** from this part.
Your composition should be about **250** words long.*

1. As a secretary of the Wildlife Club in your school, present the minutes you wrote at the first meeting for the term.
2. Write an article for publication in your school journal describing a trip you made to a tourist site and **one** lesson you learned from the trip.
3. At one time or another, most of us have to share something with someone else. Tell your friends about **one** difficulty you faced when you had to share something you value with another person and how you solved the problem.

PART B
READING
[20 marks]

4. *Read the following passage carefully and answer all the questions which follow.*

My friends and loved ones can be found all over the country. Among my numerous names are Akple, Etsew and Banku, which is my favourite name. I am made from a batter of corn and cassava dough. The taste and preference of the cook or consumer determine the proportion in which the ingredients are mixed. I am a source of carbohydrates, so, diabetics and people watching their weight should eat me in moderation.

I became popular in 1983. There was drought throughout the country and Yellow corn was supplied as food aid. The resourceful Ghanaian soaked and milled the corn. The dough was cooked as Banku. I have become a favourite dish of many people because I am easy and quick to cook. The ingredients used in preparing me are readily available and cheaper than others. Moreover, any stew, sauce or soup is a good companion of mine. Last but not least, mothers who are introducing solid food to their babies need not look any further.

Banku is a friend of all and sundry. Therefore, whenever you are unsure of what to have as your next meal, I am worth considering.

- (a) When did Banku become very popular?
- (b) List **two** reasons why Banku is a favourite dish in Ghana.
- (c) “The taste and preference of the cook or consumer determine the proportion in which the ingredients are mixed.”
What information does the writer give us in the statement above?
- (d) What do you think is a disadvantage of eating Banku?
- (e) Explain in your own words, the following expressions in the passage:

- (i) *in moderation*
 - (ii) *need not look any further*
 - (iii) *worth considering*
- (f) For **each** of the following words give another word or a phrase that means the same and fit into the passage:
- (i) popular
 - (ii) batter
 - (iii) supplied
 - (iv) readily
- (g) Summarising
- (h) In **one** sentence of not more than ten words, state the main idea of the last paragraph of the passage.
- (i) Suggest a suitable title for the passage.

PART C
LITERATURE
[10 Marks]

Answer all questions in this section correctly. Read the extract carefully and answer the questions below.

Lawrence Darmani: *Scribbler's Dream*

- 14 Tell you the truth:
15 the gold adorning the neck
16 Once was lost in rocky soils
17 They dig deep who find it!

- (a) What literary device is used in line 17 in the above extract?
- (b) What meaning are lines 14, 15 and 16 conveying?

V. B. Aakye: *The Colour of God*

The damask and aquamarine

16 If you doubt me.....

- (c) Complete line 1b of the above poem.

If you doubt me.....

Peter Paul Adolinama – *Ripples*

It was ironic that while the bride was unhappy,

She was the envy of all

the young women in town.

- (d) Who was being referred to as bride in the extract above?
- (e) The above extract depicts the theme of.....
- (f) What dominant device is used in the above extract?

(Prose) Jean Watson : *The Old man and his children*

As the boys watched, their father tied these firmly together. Then he handed the bundle to his oldest son and said “Try and break that”.

- (g) How many sticks were tied to make the bundle?
- (h) Why could he not break it?

Drama – Ama Ata Aidoo – *The Dilemma of a Ghost*

1st Woman: If her son gets goodly bag by the month, why has Esi Kom still not.....

2nd Woman: They never ask “why”.

Is it not the young man’s wife?

1st Woman: What has she done now?

2nd Woman: Listen, I hear she swallows money as a hen does corn.

- (i) Who is being referred to as “the young man’s wife”?
- (j) What is the meaning of “She swallows money as a hen does corn”?

FRENCH

STRUCTURE AND SCHEME OF THE EXAMINATION

The examination will consist of three (3) papers. Paper 1 (Oral and Written Comprehension tests), Paper 2 (Written Expression tests) and Paper 3 (Oral Expression/ Conversation tests). However, due to logistic constraints at the moment, the Paper 3 which involves oral conversation could be on hold for a while. This aspect will be tested when the necessary logistics are put in place. Therefore, teachers are advised to devote equal attention to the oral expression/ conversation aspect of the syllabus.

(1) PAPER 1 OBJECTIVE

The paper will consist of 40 multiple choice objective questions covering listening comprehension and written comprehension all of which should be answered in one (1) hour for 40 marks.

(a) Part I: Listening Comprehension

This section will consist of 20 multiple choice questions on listening comprehension which should be answered in thirty (30) minutes. Four recorded audio tests (with five questions each) will be administered to candidates.

Each of the four listening comprehension texts should be between 40 and 60 words long. Each of the four (4) texts will be heard three (3) times. During the first hearing, candidates will only listen without writing. After the first hearing, candidates will be given two (2) minutes to study the questions. The passage will then be heard the second time after which candidates will be given two (2) minutes to answer the questions. Candidates will then have the opportunity to hear the passage for the third and final time. After the third hearing, candidates will be given one (1) minute to make necessary corrections to their choice of answers. *(Put on hold)*

(b) Part II: Written Comprehension

This section will consist of 10 multiple choice questions on written comprehension. Two written comprehension passages (with five questions each) will be administered to candidates. Each of the two written comprehension texts should be between 60 and 80 words long.

(c) Part III: Vocabulary

This section will consist of 10 multiple choice questions on vocabularies associated with any sub-strands in the Common Core Programme Curriculum for French.

PART II and Part III should be answered in thirty (30) minutes.

(2) PAPER 2 (WRITTEN EXPRESSION)

This section will consist of two (2) compulsory questions which should be answered in forty-five (45) minutes for 40 marks.

Question 1

Ten (10) questions on a specific thematic area for twenty (20) marks:

- (a) Filling out of forms, e.g. at school, at the border, at the hospital, at a course, at a programme, etc.
- (b) Providing short answers to a set of questions,
- (c) Giving information on something that happened, on a person, on a place, etc.
- (d) Giving advice to a person on certain behaviours, e.g. on what they should do to keep healthy or keep the environment clean or protect the environment, etc.
- (e) Giving directions to someone using a given map, describing where something can be using given locations.
- (f) Describing what some professionals do, where they work and the tools they use.
- (g) Other areas that demand that candidates construct or do creative writing to satisfy the given scenario.

Question 2

This part consists of one (1) essay question which shall carry 20 marks.

(3) PAPER 3 (ORAL EXPRESSION / CONVERSATION)

This paper will be a one-on-one oral test comprising three (aspects):

- (a) Self-introduction - the candidate is expected to introduce himself/herself by giving as much information as possible.
- (b) Exchange of information - the candidate needs to ask the examiner questions on five words he would pick at random.
- (c) Interaction - the candidate picks a topic on a communicative scenario (buying at a shop or market, making acquaintances at a programme, seeing a doctor, introducing someone to another, etc.), and then engages in a conversation with the examiner as in a real-life situation. The candidate is expected to use the right social codes such as greeting, using polite expressions, thanking and taking leave of someone, etc. The conversation will last about 15 minutes per candidate.

The paper shall carry 40 marks: 15 marks for self-introduction, 10 marks for exchange of information and 15 marks for interaction.

(4) WEIGHTING OF THE PAPER

When Paper 1 and Paper 2 only are administered, the weighting of the paper should be as follows:

| Paper | Marks | Scaling Factor | Sub-total | Total |
|--|-------|----------------|-----------|-------|
| 1 (Objective) Listening Comprehension | 20 | 1.5 | 60 | 100 |
| 1 (Objective) Written Comprehension | 10 | | | |
| 1 (Objective) Vocabulary | 10 | | | |
| 2 (Written Expression) | 40 | 1 | 40 | |

NOTE:

Considering the limited time left for the 2024 Basic Education Certificate Examination and logistical constraints, it is prudent to put on hold the French Paper 3, which is the oral expression. This is because the philosophy of the Common Core Programme demands that the itinerant examiners are retrained and assessed to ensure that they can satisfy the communicative demands of the paper.

When Paper 1, Paper 2 and Paper 3 are administered in the near future, the weighting of the paper should be as follows:

| Paper | Marks | Scaling Factor | Sub-total | Total |
|--|-------|----------------|-----------|-------|
| 1 (Objective) Listening Comprehension | 20 | 1 | 40 | 100 |
| 1 (Objective) Written Comprehension | 10 | | | |
| 1 (Objective) Vocabulary | 10 | | | |
| 2 (Written Expression) | 40 | 0.5 | 20 | |
| 3 (Oral Expression) | 40 | 1 | 40 | |

SAMPLE QUESTIONS**ÉPREUVE 1: Tests de Compréhension (20 marks)****Partie 1: Compréhension de l'oral**

Vous allez entendre quatre (4) enregistrements qui correspondent à quatre (4) documents différents. Pour chaque document, vous avez;

- *une première écoute, puis*
- *2 minutes de pause pour étudier les questions,*
- *une seconde écoute, puis*
- *2 minutes de pause pour répondre aux questions,*
- *une troisième écoute, puis*
- *1 secondes pour vérifier vos réponses*

Vous répondez aux questions en noircissant la lettre de la réponse juste sur la feuille de réponse.

Test 1:

Olivier va à l'hôpital central pour voir son frère et il rencontre son amie Amina en route.

Écoutez la conversation et répondez aux questions.

4. Amina dit : C'est joli ! Qu'est-ce qui est joli ?
 - A. La pharmacie
 - B. La chemise
 - C. Le chapeau
 - D. L'hôpital

5. Où va Olivier ?
 - A. Il va à l'hôpital.
 - B. Il va chez le docteur.
 - C. Il va à la maison.
 - D. Il va voir son frère.

6. Que fait le frère d'Olivier dans la vie ?
 - A. Il est pharmacien.
 - B. Il est mécanicien.
 - C. Il est médecin.
 - D. Il est infirmier.

7. Pourquoi Olivier va l'hôpital ?
 - A. Il est médecin.
 - B. Il va voir le médecin.
 - C. Il va voir son frère.
 - D. Il est malade.

8. Selon la conversation, Olivier demande à Amina....
- A. de l'accompagner à l'hôpital.
 - B. d'aller voir le médecin.
 - C. d'aller à la maison.
 - D. de devenir pharmacien.

Test 2

Dans le bus scolaire, Jean veut savoir ce que fait le père de son camarade Johnson dans la vie. Johnson lui parle donc de la profession de son père. Écoutez Johnson et répondez aux questions.

9. Quelle est la tenue de travail de Monsieur Rafael ?



10. Que fait Monsieur Rafael dans la vie ?
- A. Il est professeur.
 - B. Il est policier.
 - C. Il est docteur.
 - D. Il est avocat.
11. Où travaille Monsieur Rafael ?
- A. Au garage
 - B. A l'hôpital
 - C. Au palais de justice
 - D. À l'école
12. Monsieur Rafael est avocat. Qu'est-ce qu'il fait au juste ?
- A. Il enseigne aux élèves.
 - B. Il défend les gens.
 - C. Il soigne les malades.
 - D. Il répare les voitures.
13. Selon le texte
- A. Monsieur Dotse est juge.
 - B. Monsieur Dotse est avocat.
 - C. Monsieur Rafael défend Monsieur Dotse.
 - D. Monsieur Rafael est juge.

Test 3

En classe, le professeur demande à Geneviève de dire ce qu'elle fait chaque matin avant de venir à l'école. Écoutez Geneviève et répondez aux questions.

14. Selon Geneviève,

- A. elle reçoit l'argent avant d'aller à l'école.
- B. elle lave les assiettes avant d'aller à l'école.
- C. elle prend son déjeuner avant d'aller à l'école.
- D. elle ne mange pas avant d'aller à l'école.

15. Geneviève se réveille à quelle heure ?

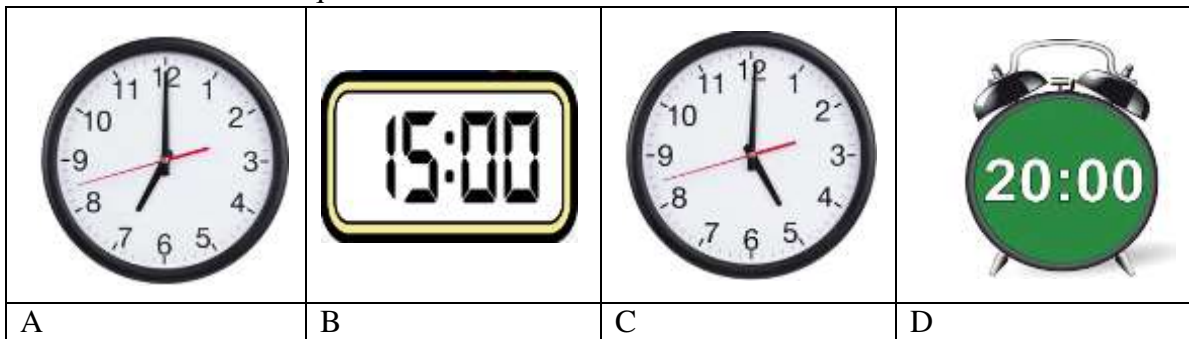

16. Qu'est-ce Geneviève fait après le bain ?

- A. Elle se lève.
- B. Elle balaie la cour.
- C. Elle salue ses parents.
- D. Elle s'habille.

17. Qui prépare le petit-déjeuner ?

- A. Le père de Geneviève
- B. La mère de Geneviève
- C. Le frère de Geneviève
- D. Geneviève elle-même

18. Geneviève vient à l'école à quelle heure ?

- A. À 6h 30
- B. À 7h 30
- C. À 5h 40
- D. À 8h 20

Test 4

Abena téléphone à Kofi pour l'inviter à sortir avec sa famille. Mais personne ne décroche l'appel. Le répondeur lui dit de laisser un message. Écoutez le message d'Abena et répondez aux questions.

19. Combien de personnes parlent au téléphone ?

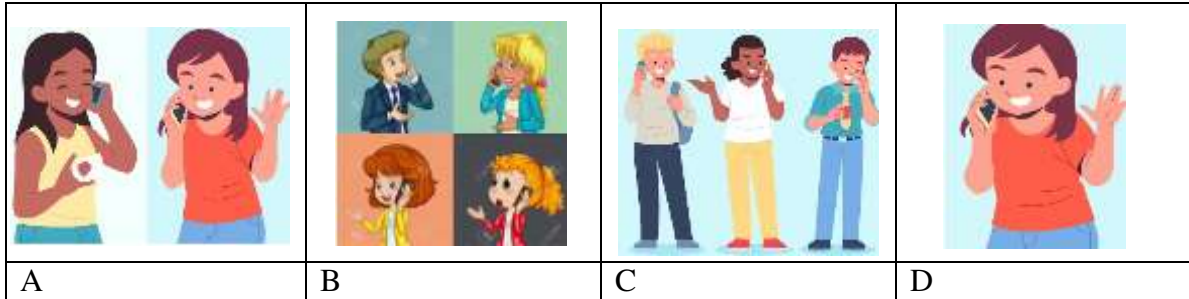

20. Où est-ce que la famille d'Abena va visiter ?

- A. Le Mausolée de Nkrumah Kwame
- B. Le jardin de Kwame Nkrumah
- C. Kwame Nkrumah Circle
- D. Le village de Kwame Nkrumah

21. Qu'est-ce que la famille va voir là-bas ?

- A. Beaucoup de choses
- B. Des choses historiques
- C. Beaucoup de nourriture
- D. Un répondeur téléphonique

22. Qui répond à l'appel d'Abena ?

- A. Le papa de Kofi
- B. La maman de Kofi
- C. Le répondeur
- D. Kofi lui-même

23. Qu'est-ce que Kofi doit faire pour partir avec la famille d'Abena ?

- A. Il doit parler à son père.
- B. Il doit visiter la place.
- C. Il doit demander à sa maman.
- D. Il doit répondre au répondeur.

Partie 2: Compréhension des écrits (10 marks)

Vous allez lire deux (2) documents différents. Pour chaque document, Vous répondez aux questions en noircissant la lettre de la réponse juste sur la feuille de réponse.

Test 1

Éric présente sa famille dans un journal des enfants. Lisez la présentation d'Éric et répondez aux questions.

Je m'appelle Éric Owusu. J'ai quinze ans. Mes parents sont Monsieur et Madame Owusu. Nous habitons une petite jolie maison dans un village. Mes parents ont un seul enfant. Papa est boulanger et Maman est mécanicienne. Mes parents sont toujours fatigués parce qu'ils font beaucoup de choses à la maison aussi. Moi, je suis élève à une école publique en ville. Je vais à l'école à vélo. J'adore ma famille ! Vous savez pourquoi ? Papa et Maman sont très gentils !

1. Eric va à l'école par quel moyen ?

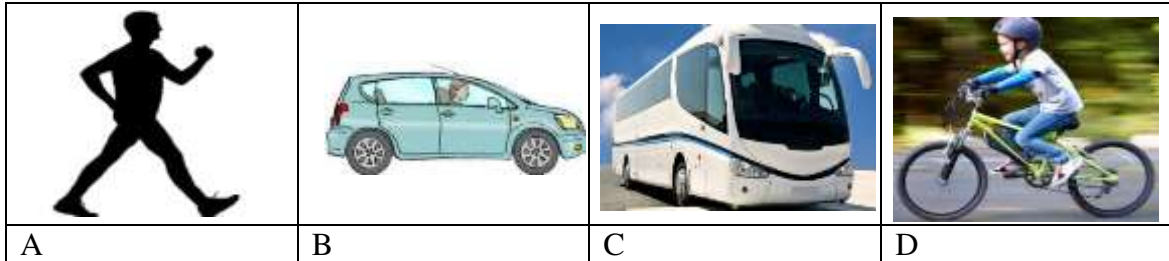

2. Selon le passage,

- A. Éric a un frère.
- B. Éric est un fils unique.
- C. les parents d'Éric ont des enfants.
- D. les parents d'Eric n'ont pas d'enfants.

3. Qu'est-ce que Madame Owusu fait dans la vie ?

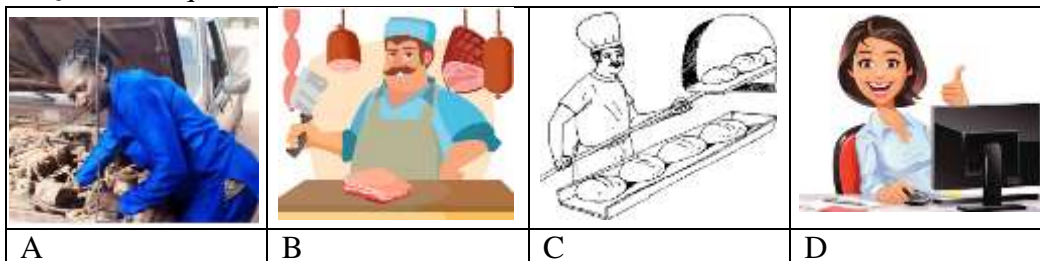

4. Selon le texte, Monsieur Owusu

- A. répare les portes
- B. répare des voitures
- C. enseigne aux élèves
- D. fait du pain

5. Éric dit que sa Maman est toujours fatiguée. Pourquoi ?
- A. Elle est paresseuse.
 - B. Elle est boulangère.
 - C. Elle est mécanicienne
 - D. Elle fait les ménages.

Test 2

Lis le texte et répond aux questions qui suivent.

Monsieur Ali envoie son enfant Bilal à l'hôpital pour voir le docteur. Lisez leur conversation et répond aux questions qui suivent

- Au revoir Bonjour Docteur
- Bonjour monsieur
- J'ai rendez-vous avec vous.
- Qu'est qui ne va pas ?
- Mon enfant est malade. Il a mal à la tête.
- Je vais l'examiner. Je veux prendre sa température. Oh votre fils a la fièvre. Voici les médicaments.
- Merci docteur

26. Combien de personnes parle dans le dialogue ?

- A. 2
- B. 3
- C. 4
- D. 5

27. Le père de Bilal dit qu'il a mal où ?

- A. Au ventre
- B. au dent
- C. a la tête
- D. a la main

28. Qui est malade ?

- A. Personne
- B. Parent
- C. Docteur
- D. Un garçon

29. Le père de Bilal l'amène à l'hôpital

- A. pour saluer le docteur
- B. pour rendre visite aux malades
- C. pour le faire soigner
- D. pour avoir rendez-vous avec le docteur

30. Qui donne les médicaments au malade ?
- A. Un pharmacien
 - B. Un enseignant
 - C. Un docteur
 - D. Un avocat

ÉPREUVE 2 : Production écrite**Tâche 1 (exemple 1) (10 marks)**

C'est votre premier jour à une école secondaire en Côte d'Ivoire. Le directeur vous donne cette fiche d'inscription à remplir avec vos informations du Ghana. Remplissez-la.

| |
|--|
|  <p>Lycée Classique d'Abidjan Av. Aka, Abidjan, Côte d'Ivoire</p> |
| <p>Année Scolaire : 2023-2024 <u>Fiche d'inscription</u></p> |
| <p>1. Nom:</p> <p>2. Prénom :</p> <p>3. Ville natale/village natal :</p> <p>4. Adresse résidentielle :</p> <p>5. Date de naissance :</p> <p>6. Profession de votre père</p> <p>7. Matière préférée :</p> <p>8. Plat favori :</p> <p>9. Jeu préféré :</p> <p>10. Contact des parents :</p> <p>Signature :</p> |

Tâche 1 (exemple 2)

Vos amis sont venus chez vous. Dans votre salon c'est la photo et l'arbre généalogique de votre famille. En dix phrases, décrivez la famille à vos amis.

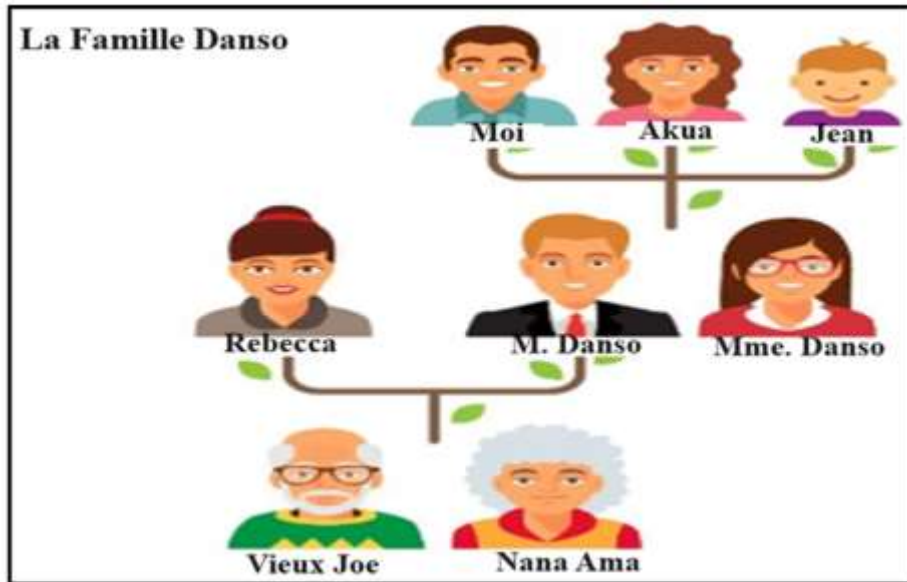



- i.
- ii.
- iii.
- iv.
- v.
- vi.
- vii.
- viii.
- ix.
- v.

Tâche 2 (20 marks)

Vous recevez cette carte d'invitation de votre amie Julie à son anniversaire. Mais vous ne sera pas libre. Répondez à votre amie pour refuser l'invitation et donnez des raisons.

(40 à 60 mots)

| | |
|---|--|
|  | <p>JE FÊTE MON ANNIVERSAIRE ! Coucou, cher ami ! J'aurai bientôt 16 ans ! Hurrah !</p> <p>Je t'invite à fêter mon anniversaire avec moi le samedi 9 mars 2024 à 10h. La fête aura lieu chez mon père au 3, rue Coconut Avenue, Asylum Down, Accra Viens fêter avec moi ! Apporte-moi un joli cadeau.</p> <p>A très bientôt ! Julie</p> |
|---|--|

| | |
|--|--|
|  | <p>.....</p> <p>.....</p> <p>.....</p> <p>.....</p> <p>.....</p> <p>.....</p> <p>.....</p> |
|--|--|

Compréhension de l'oral – Transcriptions (To be recorded)

Test 1

- Ah ! Olivier ! C'est toi !
- Oui, Amina, Bonjour !
- Bonjour ! J'adore ton chapeau ! C'est joli !
- Merci beaucoup.
- Où est-ce que tu vas ?
- À l'hôpital central.
- Mais tu es malade ?
- Non, je rends visite à mon frère aîné. Il travaille là-bas.
- Ah bon ! Il est médecin ?
- Non, il est pharmacien. Tu peux m'accompagner ?
- Oui, avec plaisir !

Test 2

Le nom de mon père est Rafael. Il est avocat. Il travaille dans son cabinet et au palais de justice. Il défend ses clients contre l'injustice. Il prépare et signe aussi des documents pour ses clients. Papa travaille avec les juges, par exemple, Monsieur Dotse. J'aime beaucoup le travail de Papa. Moi aussi je veux devenir avocat comme Papa.

Test 3

Je suis étudiante donc je me lève très tôt le matin. D'habitude, je me réveille à 5 heures. Tout d'abord, je fais mon lit et je me brosse les dents. Ensuite, je balaie les chambres et la cour, et puis je me lave. Après le bain, je m'habille. Normalement, mon grand-frère prépare le petit-déjeuner. Quand je finis de prendre mon petit-déjeuner, je reçois mon argent de poche, dis au revoir à mes parents et je viens à l'école. D'habitude, j'arrive à l'école à 6h30. Merci.

Test 4

'Votre correspondant n'est pas disponible pour le moment. Merci de laisser un message vocal.'
Bonjour Kofi ! C'est Abena. Ce week-end, ma famille va faire une sortie au Parc Kwame Nkrumah. Je t'invite à sortir avec nous. Nous allons voir le Mausolée et des choses historiques du Dr. Kwame Nkrumah. Nous allons rencontrer des amis aussi. Maman va préparer alors il y aura beaucoup à manger. Tu viens ? Demande la permission à ta Maman. Rappelle-moi vite ! À bientôt !

GHANAIAN LANGUAGE

STRUCTURE AND SCHEME OF THE EXAMINATION

The Examination will consist of two (2) Papers (1 and 2), both of which must be taken at a sitting.

1. PAPER 1 (OBJECTIVE)

This will be a 50-minutes Compulsory Objective Paper of 40 questions for 40 marks. The Paper will cover Customs, Institutions, Oral & Written Literature and Listening and Speaking.

2. PAPER 2 (ESSAY)

This will be 1 hour 10 minutes Paper consisting of four (4) parts for 60 marks. This will consist of Composition, Comprehension, Translation and Language and Usage.

3. WEIGHTING OF THE PAPER

| PAPER | MARKS | SCALING FACTOR | TOTAL MARKS |
|---------------|-------|----------------|-------------|
| 1 (Objective) | 40 | 1 | 100 |
| 2 (Essay) | 60 | 1 | |

SAMPLE QUESTIONS**DANGME****PAPER 1****40 MARKS**

Moo hla heto nɛ da pe kulaa kɛ ha bimi nɛ ɔmɛ.

1. Ligbi enyɛmɛ lɛ bimwɔyo yeɔ loko a jeɔ lɛ kpo ngɛ Dangme je?
 - A. Ekpa
 - B. Kpaago
 - C. Kpaanyɔ
 - D. Nɛɛ

2. Dangme je gba komɛ ji.....
 - A. Pla gba, Sɛheyo gba, Jeyo gba
 - B. Lɛlɛssiyo gbam Weku gbam Kabolaiyo gba
 - C. Yalɔyo aloo ahoyo gba, sɔlemi tsumi gba, mase gba
 - D. Wɔyokus gba, Klamɔ gba, ni tsumi he gba

3. Hla Dangme je wetso nguahi ngɛ wetso nɛ ɔmɛ a kpɛti.
 - A. Piɛngua, Tɛkpɛbiawɛ, Bunase Loowɛ
 - B. Nyɛwɛ, Kabubiawɛ, Jebiam, Ohuɛwebiawɛ
 - C. Dangmebiawɛ, Okpɛ, Ogɔmɛbiawɛ
 - D. Lomobiawɛ, Plau, Kɔgbɔbiawɛ

4. Nɔ nɛ ɔ piɛɛ nihi nɛ a hyɛ ɔmɛ a he loko a woɔ nɔ ko matsɛ ngɛ Dangme je.....
 - A. Nɔɔ ɔ sukuu nɔ kuɔmi
 - B. Kaa e je matsɛ womi we mi lo
 - C. Kaa e ngɛ sika lo
 - D. Kaa e be yo ngɛ e tsu nya

5. Tsɔɔ gbimikɔmi okadi he ni nɛ a tsu ngɛ pɛlɔ /e/ nɔ ngɛ munyungu tade mi.
 - A. Sisi gbimikɔmi
 - B. Kpɛti gbimikɔmi
 - C. Hiɔwe gbimikɔmi
 - D. Kɔɔfu gbimikɔmi

6. Tsɔɔ gbimikɔmi okadi he ni nɛ a tsu ngɛ pɛlɔ /i/ nɔ ngɛ munyungu otimi mi.
 - A. Sisi gbimikɔmi

- B. Kpɛti gbimikɔmi
 C. Hiɔwe gbimikɔmi
 D. Kɔɔfu gbimikɔmi
7. Tsɔɔ pɛmingu mi pomi aloo mi gbami nɛ da ngɛ munyungu asafoatsɛ mi
 A. asafoɔaɔtsɛ
 B. aɔsafoɔaɔtsɛ
 C. asaɔfoɔaɔtsɛ
 D. aɔsaɔfoɔaɔtsɛ
8. E ho Mawu a je pa ya a, sisi ji mɛni?
 A. Mawu tsɔ lɛ pa mi
 B. E ngɔ hɔ
 C. E ho pa ko nɛ a pee ha Mawu ya
 D. Mawu tsɔ lɛ kɛ ho e neneene pa mi ya
9. Yi hi si nɛ nakutso buɔ pɛɛ peeɔ.....
 A. Aguasemi gbi
 B. Abɛ
 C. Asɛslɛ
 D. Nakpatawomi
10. Nyazia nya blimi munyu ji.....
 A. Agoɔɛ
 B. I tiaa nyɛɛ
 C. I ngɛ lejs ɔ niinsɛ
 D. Nyɛ ha waa sia nyaziaɛ
11. Ni nɛ ɔmɛ a kpɛti kake piɛɛ we bimwɔyo tɔtɔmi aloo mɔlemi la he se nami ɔmɛ a he.
 A. E woɔ bimwɔyo ɔ bua
 B. Bi ɔ kɛ kaseɔ gbi
 C. Ni kpahi nɛ a kase la amɛ
 D. Binyɛ ɔ naa deka kɛ peeɔ e nihi.

Kane nyazia nɛ ɔ, konɛ o ha bimi Ōɛɔɛfɛ nɛ nyɛɛ se nɛ ɔmɛ a heto.

Kabu ji binyumuyo ko nɛ e kɛ e fɔli mɛ hi ma ko nɛ a tsɔɔ lɛ ke Ebaajadaa a mi

E fɔli fiɛ we e he kulaa ejakaa e hɛ mi wa kɛ ni tsumi. Ligbi ko ɔ, Kabunye hyɛ blɔ kaa e bi wɔ maa je e ni tsumi he kɛ ba we, “Kabu we mi bɛmi mwɔnɛ ɔnɛ ekoa ba pee kaa Padi sane ɔ nɛ nɔ ko li he nɛ e ngɛ kɛ ba si piɔ ɔ. Peese ɔ, nɔ ko ya oslaa nɛ e nɔ mi amlɔ nɔuu. Sane ɔ hao Kabunye nɛ e de ke “Gbenɔ, o yi mi wa tsɔɛ”

12. Mɛni ji oti pɔtɛɛ ngɛ nyazia a nɛ o kane ɔ mi?

- A. Kabu hɛ mi wami kɛ ni tsumi
- B. Kabu ni tsumi yami ligbi ko
- C. Kabu laami kɛ e hlami
- D. Kabu oslaa name kɛ e gbenɔ

13. Mɛnɔ he nɛ nyazia a kɔ?

- A. Padi
- B. Kabu
- C. Kabunye
- D. Ebaajadaa

14. Mɛni munyu he za wolɔ he ni a tsu ngɛ demi, “Kabu we mi bɛmi mwɔnɛ ɔ nɛ eko ba pee kaa Padi sane ɔ nɛ nɔ ko li he nɛ e ngɛ kɛ ba si piɔ ɔ”.

- A. Kaalɛ / ejelɛ
- B. Lɛngmengmlee
- C. Apelɛbɔ
- D. Nyakpatawomi

15. Mɛni munyu mi zɔ womi munyu ji “Gbenɔ, O yi mi wa tsɔ” ɔ?

- A. Apeelɛnɔ / adɛsu
- B. Lɛngmengmlee
- C. Kaalɛ / ejelɛ
- D. Nyakpatawomi

PAPER 2

This paper consists of four parts: I, II, III, and IV. Answer one question only in part I and all the questions in Parts II, III and IV.

Answer all questions in your answer booklet.

Credit will be given for clarity of expression and orderly presentation of material.

PART I
COMPOSITION
30 MARKS

1. Ngmaa saneyo nɛ e nya kɛmi ko ba si pe munyu ngu lafa kake kɛ nyingmi enuo nge munyutso nɛ ɔmɛ a kpɛti kake pɛ he.
 - a. O ya na hus he ko nge sukuuhi a fiɛmi kedimi aloo Kolisimi be ɔ mi. Ngmaa saneyo ya ha lɛ nɛ o kɛ de lɛ bɔ nɛ o bua jɔ fiɛmi ɔmɛ a he ha.
 - b. Moo kale bɔ nɛ a hooɔ niye ni ko nɛ o suɔ pe kulaa a ha.
 - c. Daa Hɔ ɔ, o na we deka. Ngmaa kɛ tsɔɔ o hushi nihi a he je nɛ o na we deka nge Hɔ ligbi ɔ nɔ nge.
 - d. Ngmaa kɛ tsɔɔ he nɛ o maa suɔ nɛ o hi, Ghana aloo ablotsi.

PART II
COMPREHENSION
10 MARKS

2. Nyumu ko kɛ e yo hi kɔpe ko nɛ a tsɛɔ lɛ ke Wanɔngɛmi ɔ mi. A nge biyi enyɔ, nɛ a bis ji Dede kɛ Kɔkɔ. A papaa si je mi nge a jokuɛwi a si. Jeha kake se ɔ, a nyɛ ɔ hu ba si je mi.

Se lokoji a nyɛ ɔ ma gbi ɔ, e tsɛ e bi, Dede kɛ ba e sa a he nɛ e de lɛ ke, “I be he wami kulaa, nɛ I nge gbeye yee kaa i ma si ngi tɔ atia. Enɛ ɔ he je ɔ, I nge O senɔ, Kɔkɔ sie kɛ nge mo ha nɛ o hyɛ e nɔ. Ke e wa a, o hyɛ nɛ o ngo lɛ kɛ ha nyumu kpakpa ko nɛ e ngo lɛ.

Ke e fɔ bime ɔ, hyɛ e kɛ e bime ɔmɛ a nɔ, hɔyɛ e kɛ e bime ɔmɛ a nɔ, konɛ o tsɔse e bi ɔmɛ kaa bɔ nɛ o ma tsɔse mo nitɛ o bime. Mo wo nihi nɛ I nge kɛ nihi tsuo nɛ I kɛ ke mo ɔ kɛ hyɛ a nɔ”.

Dede wo si kaa e maa pee kaa bɔ nɛ e nyɛ ɔ de lɛ ɔ. E ye enyɛ ɔ si womi ɔ nɔ pɛpɛpɛ kɛ ya si igbi ɔ nɛ a ye a kusumi jeha a. Dede wo e kuɛ ni aloo kuɛ ga a kɛ ha e senɔ, kɔkɔ konɛ e kɛ ye jeha a. Se he ni bemi nya a, kuɛ ga a ya laa.

- a. Binie enyɛmɛ nɛ nyumu ɔ kɛ e yo ɔ nge?
- b. Meni be mi nɛ bi ɔmɛ a fɔli ɔmɛ si je mi?
- c. Meni ji demi, “si ngo tɔ atia a sisi kaa bɔ nɛ a tsu e he ni nge demi yo ɔ mi ɔ?”
- d. Moo hla munyu he za wolo kake kɛ je demiyo ɔ mi.

- e. Mɛni he je o susu kaa jokuɛwi ɔmɛ a nyɛ ɔ si kɔkɔ ha Dede ke e hyɛ e nɔ ɔ?
- f. Mɛni munyu he za wolo he ni a stu ngɛ demi, nɛ e ngɔ lɛ ɔ mi ɔ?
- g. Mɛni he je nɛ Dede wo kuɛ ga aloo kuɛ ni ɔ kɛ ha kɔkɔ ngɛ ɔ?
- h. Kɛ kuɛ ga a aloo kuɛ ni ɔ plɛ kɛ laa kɛɛ?
- i. Kɛ o susu nɛ Dede kɛ e senɔ a huɛ bɔmi aloo si himi maa hi kɛɛ ngɛ kuɛ ni ɔ laami se?
- j. Ngɛ munyungu nɛ e hismi ko pee kpaago mi ɔ, ha demiyo nɛ ɔ biɛ nɛ sa lɛ.

PART III
TRANSLATION
10 MARKS

- 3. Mo je munyuza nɛ ɔmɛ a sisi kɛ ba dangme nyaii mi.
 - a. The students were rewarded for their performances.
 - b. I saw a snake in the bush on my way to school.
 - c. It rained heavily this morning.
 - d. The teacher is very thirsty.
 - e. The harmattan is very severe this year.
 - f. Who came here yesterday?
 - g. You must be careful on the road.
 - h. Kofi ate all the food on the table.
 - i. The big black cat jumped over the wall.
 - j. Why do people cheat others so much in this country?

PART IV
LANGUAGE AND USAGE
10 MARKS

Ngmaa munyungukuu mi ne munyunguhi ne a po sisi omɛ ngɛ.

- a. Yo ne ɔ he ngɛ fɛu nitse.
- b. Nyumu ɔ ke e yo ɔ hia blɔ hiɛ.

Ngmaa hefohi ne da ke gbe munyuza ne omɛ a nya.

- c. Munyuza ne heɛ peemimunu kake ji.....
- d. Munyuza kpanya a ngɛ dɛhe munyukpɔ kake ke.....
Munyukpɔ kake.
- e. Mɛni munyuza henɔji enɛ ɔ?
E yɛ sukuu ejakaa e be he wami
- f. Ngmaa munyuza kpanyaa kake.

Ngmaa munyuza ne omɛ ekohu, konɛ o tsu ni ngmami mi okadihi ne sa a he ni ke eko fɛɛ eko mi.

- g. E he hyɛ, tomatosi ke ga aloo agblitsa
- h. O ye niye ni ko mɔtu ne ɔ lo

Ngmaa munyu ne omɛ ngɛ a dadɛ blɔ nɔ.

- i. bua mi jɔ
- j. takoto

DAGAARE
PAPER I
OBJECTIVES

Soorebiri kaɗazaa taa la nɛ iribu parɛ anaare; A te ta D. Kaa iri onan tori ne soorebiti. Pãã kaa a nɛ iribu gampɛle na poɔ a penti daga na noɔre nan tori ne a noɔre na fo nan iri, ne pensel.

Kaa iri a nɔ-irri A–D poɔ, onan nan tori ne a soorebiri.

1. Dagaaba lanɗkpeɓon, ka banan wa pore dɔlee yuori ka Dakoraa, a wuli ka.....
 - A. Ba dɔge o la ka o kore
 - B. Ba dɔge o la ka o taa dakoraa / dagoli
 - C. Ba dɔge o la dɔlee ka o kpi kye ba la dɔge dɔlee
 - D. Ba dɔge o la dakoree poɔ

2. Nee nan man kyere dɔ pɔge dɔ pɔge dɛndɛn la a dɔ.....
 - A. Areba
 - B. Meɗɗe
 - C. Saanɗkoma
 - D. Saa

3. A e la kyiiroŋ kpoŋ ka bal yeni noba ta ere boŋ?
 - A. Belle taa
 - B. Kulo taa
 - C. Lanɗ kpeere
 - D. Zɔɔɔ taa

4. Am akaŋa la so ka noba Dagaaba lanɗkpeɓon ba la buuro naalon?
 - A. Naasaalaa kɔto yie la
 - B. Naalon diibu ba la taa gyereɗe
 - C. Nee ma tɔɔ ŋme la naa kye ka a we
 - D. Nob aba la wuro naa dakogi

5. Kɔkɔgaale Dagaaren man wullo la.....
 - A. Yelbiri boole duubu bee o sigibu
 - B. Yelbiri segebo yeɗe poɔ
 - C. Yelbiri paabo a puluu zie
 - D. Yelbiri segebie noɔre poɔ boɔloo

6. A kàkàgaale a yelbiri bàà pò wuli ka a yelbiri tɛgɛ la.....
- Nɔwogi
 - Bibile naŋte leɛ neŋkpoŋ
 - Mane
 - Z—wiri gara ne
7. Wuli a kàkòtɛgre noore naŋ be a yelbiri bebela pò.
- Ayi
 - Boniyeni
 - Anaare
 - Ata
8. Sekpɔgɔ waa la yɛŋ tegerɛ yɛɛ bonso a taa la.....
- Nɔkpɛɛ—ŋmɛ
 - Yɛŋ zuluŋ
 - Tɛŋɛ sensellɛ
 - Yɛŋ dɛdɛrɛɛ
9. A bie nii ba kpeɛrɛ zage wuli ka o.....
- Ba yeke yelmenne
 - Nii ba gana zage pò
 - Nii ba taa zage
 - Yɛɛ zuoke la
10. Bal tensere gandaalon bee berebo sensellɛ la a ama buosoba?
- Don—ŋmaa—kyɛ—ko—taa
 - Donsellɛ
 - ŋmensellɛ
 - Saadayel
11. Biyaale yiele tònò kaŋa la a naŋ maŋ soŋ ka a bie ma yieli yieluŋ.....
- Gyɛsɛ ne o yontaa kyɛ ka a wɛ
 - To ne a biyaala kyɛ ka o ba baŋ
 - Pugi ne a bie wetaaba
 - Digi a bie tɛroŋ gyereɛ bare
- Kanne a senselloo ŋa naŋ tu velaa kyɛ iri a soorebie nɔ.

Batuuri bayi mine la da bebe a ba yire. Ba yoe da la kaara-eebo ane kaatori. Ba da yi la Lesnyɛ. Ba da gɛrɛ la Bɛllenyɛ Sekundere Sakuuri. Ba da laɗ la diganaa a sakuuri poɔ.

Ɔmentantuo kaɗa, kaaraa-eebo da sɔre la sori na gaa teɗe poɔ te da sense eɗ noɔreɗ, a vɔlaa naɗ da kpe o zuɗ. Kaatori da beɛɛ o la gaa ne. Kaaraa-eebo da moɗ o la. A le da d—la Kaara-eebo da ba de kya o.

A ɗaa zuɗ, a zɔmenne bama da ba la nyɛrɛ taa te gaa kyuu gbuli. Daare kaɗa, kaatori da leɛ kaa nyɛɛ la ka a dɔɗ ɗa naɗ be a ba kpakyagaɗ ba soma. O da gaa gbi la dumo Kaaraa-eebo niɗeɗ a na nyɔge o duni kye ka nentaɗ zoro. Kaaraa-eebo meɗ da nyɔge la omeɗe guo kye meɗ taala boɓɓo. A yi a le daare, a ba baaloɗ da leɛ kpe la taa aɗa beɗe ne kãã na, la saeɛ ba la tuuro yire ba sogaaɗ te ta saɗa na naɗ bare a sakuuri.

12. A sensello ɗa yelnyɔgeraa la boɗ?

- A. Sudi sɔrebo
- B. Zɔmenne bayi
- C. Sense zɔre
- D. Bɛllenyɛ Sekundere Sakuuri

13. A deɛdeɛkaraa a sensello poɔ la.....

- A. Kaaraa-eebo
- B. Kaatori
- C. Sense maala
- D. Sakuuri karemaɓuzɛɛ

14. Boɗ yelkaama gɔɔrombiri la a leɛ kpe la taa aɗa beɗe ne kãã?

- A. meel-eɗ
- B. nensaaloɗ
- C. segebie pulluu
- D. damanna

15. A yelluu ɗa saseɛ ba la tuuro yire ba sogaaɗ e la.....

- A. Mee-eɗ
- B. Nensaaloɗ
- C. Segebie pulluu
- D. Damannaa

PAPER 2
PART 1
30 MARKS

1. Kaa iri a yelzuri ama kaɲa boɲyeni a sɛge ne yelyagesɛgeraa ka a yelbie na ta ɛfɛ
 - a. Fo da nyɔge la zɔmɛɲ / kyɛɲ kaɲa a sakue zogantaa ne bɔɲɛ kirinɛ naɲ pare zie. Sɛge lɛtɛ / gane ko o a manne lɛɲɛ fo naɲ woɲ noɔ a zogantaa lamma zie.
 - b. Manne wuli lɛɲɛ ba naɲ maɲ maale fo bondinɔnaa.
 - c. Fo maɲ tonɔ la toma moɔ nimiri Yɔdaare beguo zaa. Birigi ko fo zɔmenne / kyɛmmine bin na toma fo naɲ maɲ moɔ a nimiri tona.
 - d. ɔmɛ nɔkpeɛne wuli paalonɲ na poɔ kpeɛho fo naɲ boɔɔ, Gaana bee Tuuree.

PART II
COMPREHENSION
10 MARKS

2. Kanne a yelyagesɛgeraa ɲa vela kyɛ pãã iri a soorebie na zaa naɲ tu nɔɛ.

Dɔɔ kaɲa ne o pɔge la da kpeɛɛ tembile kaɲa ba naɲ boɔɔ Zaguɔ. Ba da taa la pɔgeyaare bayi, Pɔɔpore ane Taazomɔ. Ba saa da kpɛ la a saɲa na ba naɲ waa bilii lɛ. Ba saa naɲ kpi ka a pare youngbuli la k aba meɲ kpi.

Ne-a-zaa k aba ma naɲ na kpi la, o da boole la Pɔɔpore ka o tage ta O lombori, ka o yeli, “Nbeɛɛ la yaga a taa dabɛɛ ka amine kaɲa N eeke na ba la tɛɲɛ. ɲaa zuiɲ, N de la Taazomɔ ko fo ka fo kaara. Kaara o vela. Ka onɲ wa baa de o ko dɔɔ naɲ na vɛɲ ka o poli kããkõõ. Ka onɲ wa dɔge biliiri kaara o laɲ ne o bibiiri. De a o biriiri aɲa bon-la-bonzaa N naɲ taa a bre ko fo a kaara ne ba.

Bɔpore da pole la noɔre ka o na tonɲ la lɛ o ma naɲ yeli ko o. A yi a noɔre o naɲ ɛɔ ko o ma zuiɲ, o da kaa la o yɔlee na vela a taa lɛɛ te ta tigiri kaɲa ban aɲ maɲ maale bateɲɛ poɔ. Bɔpore da le la salema kɔkɔlɛgɛ ko Taazomɔ ka o ɛɲ di ne a tigiri. O zu da ba nom aka kɔkɔlɛgɛ bɔre.

Soorebie.

- a. Bibiiri bawola ka dɔɔ ne o pɔge da taa?
- b. Dabuo saɲa ka bibiiri da kɔɲ ba dɔgereba?
- c. A yelɲmaa ɲa eele na ba la tɛɲɛ tɛgɛ la boɲ?
- d. Kaa iri yeldegrenaɲ be a dɛmmo poɔ.
- e. Fo tɛɛre ka bonso k aba ma da bare. Taazomɔ ko Pɔɔpore ka o kaara.

- f. A gɛɛrombiri ɲa o poli kɛɛ kɔɔ la buo?
- g. Bonso ka Pɔɔre de a salema kɔkɔɔɔgɛ ko Taazomɔ?
- h. Wola ka kɔkɔɔɔfi gɛ e bɔre?
- i. A kɔkɔɔɔgɛ naɲ bɔre wola ka fo tesre k aboɲ na be a yɔɔpɔgeba bama kpakyaganɲ?
- j. De yelbie naɲ koɲ pare ayopoi a sɛge ne yelzu ko a dɛmmo ɲa.

PART III
TRANSLATION
10 MARKS

Lɛsre a yɛɛ ama naɲ tu eɲ fo kɔkɔɔɔɲ

- a. The students were rewarded for their performance.
- b. I saw a snake in the bush on my way to school.
- c. It rained heavily this morning.
- d. The teacher is very thirsty.
- e. The harmattan is very severe this year.
- f. Who came here yesterday?
- g. You must be careful on the road.
- h. Kofi ate all the food on the table.
- i. The big black cat jumped over the wall.
- j. Why do people cheat others so much in this country?

PART IV
LANGUAGE AND USAGE
10 MARKS

Sɛge a yelbie anaɲ soɔmaa naɲ toɔne a parɛɛɲ yelbie gangyere

- a. A pɔge ɲa vɛɛɛ la yaga.
- b. A dɔɔ ane o pɔge tu la sori zaameɲ

De ayelbie anaɲ naɲ seɲ ne furi ne a vɛɛ naɲ be a yɛɛ ama poɔ

- c. Yɛɛ naɲ ta aereɲ boɲyeni yoɲ la ka ba boɔɔ.....
- d. Yelleremɛ e la yɛɛ naɛ taa yelgbɔge sommeɲɛ boɲyeni ane.....
yelgbɔgre.

Iri a soorebie ama ka a tu

- e. Ayɛɛ ɲa naɲ tu e la gangye buo?

“O da ba gaa sakuri bonso o beere la”.

f. Sɛge yelleremɛ yeldemanna.

Enj tɛgoo yeldemanneulli a yeɛ ama poɔ

g. O da la waare, toose ane kombie

h. Fo di la bondiraa zaa a beguo ŋa

Leɛ sɛge a yelbie ama ka a tu

i. Eɛɔpɔ

j. Oteɛɔ

DAGBANI
PAPER 1
OBJECTIVE

Lihimi A Zaɗ chan D puuni n labisi bɔhisi din doli ɲɔ na viɛnyɛlinga.

1. ɛLoori yi ɲme so ka o nya daɲa, ka a chaɲ ni a ti puhi o, wula ka a yɲ puhi o? Ni ti.....
 - A. sarati
 - B. dali maa
 - C. zuɣusuɲ
 - D. soha maa

2. Paɣa yi dɔɣi bia m–pa jɛbihi zuɣu, Dagbama booni bia maa la
 - A. Napari
 - B. Nabia
 - C. Naama
 - D. Nasaxiri

3. Paɣa yi be doo yili ka bi dɔɣira, bɛ booni o la paɣa.....
 - A. ɲoo
 - B. ɣinli
 - C. Doo
 - D. ɣiɛɣu

4. A badɔɣiro mi badɔɣiro nyɛla a.....
 - A. Yaɲa
 - B. Piriba
 - C. Yaba
 - D. ɲahiba

5. Paɣa yi kani ka bɛ sɔɣi o naai, daba a ta dali ka bɛ lɔɣiri o bɔɣili
 - A. anahi
 - B. ata
 - C. anii
 - D. anu

6. Dagbaŋ kali soli zuƙu, doo y obo paƙa ka yen suhi o ka o kuna, bɔ ka bɛ mali chana?
- A. Bua
 - B. Noo
 - C. Guli
 - D. Chinchini
7.tooi tahiri doo mini paƙa taba chɛbu na.
- A. Nama kalinsi
 - B. Bindirigu kalinsi
 - C. Dooshee kalinsi
 - D. Kom kalinsi
8. Saamba yi chaŋ Nayili, Naa tirila.....
- A. Guli
 - B. Liyiri
 - C. Neenyera
 - D. Kom
9. Chimsi chuƙu ni, Naa chuƙu puhirila.....
- A. Asibaasi
 - B. Wuntaŋ ni
 - C. Zaawuni
 - D. Yuŋ
10. Linsi yi salindi so Buƙuyɛligu yili nachima cheyuri barikori nachima. Di wuhirimi ni.....ka o yima.
- A. Kariga
 - B. Naya
 - C. Sunsoŋ
 - D. Tolon
11. Dagbamba yi yen maali baƙyuli, o pirigiri la a.....
- A. Liiga
 - B. Baƙa
 - C. Namda
 - D. Jinjem

PROSE

Karimmi kariŋ ɲo ka labisi bɔhisi ɲan doli maa.

Azindoo nyɛla daabia. Lala zuɣu biɛɣukam o gindila tiŋkpansi n-kɔhiri o niɛma Azindoo malila paɣa ni bihi Anahi, bipuɣinsi ayi ni bidiba ayi. O daabitali ɲo zuɣu o ka saha wumsiri bihi ɲo sɔŋdi bɛ ma. Lala zuɣu bihi maa daa niɲa biyoya. Bihi maa, dibahibamdi bidibsi maa daa leela vanyurba ni ti vandiba.

Azindoo paɣa samata nii da nya yɛla maa ni chani shɛm maa, o daa yɛlila o yidana ni o chɛti o daabili gu ma aka zaŋ o zaɣa niɲ bɛ bihi maa wubsibuni.

12. Azindo tuma daa lee nyala dini.

- A. Nakoha
- B. Pukpara
- C. Daabia
- D. Naɣkpara

13. Bihi al aka Azin doo dɔɣi

- A. Ayobu
- B. Anu
- C. Amahi
- D. Anii

14. Bɔzuɣu ka Samata yɛli Azindoo ni o chali o daabiligu maa?

- A. Ni ba kɛ wumsi bihi maa visnyɛla
- B. Ni ka bɛ gberi kum
- C. Ni ka bɛ wari waa
- D. Ni ka bɛ zia vuhira

15. Zaɣa niɲ wuhirimi ni o.....

- A. Kpaŋsim bihi maa wumsibu polo
- B. Fiɛbimi bihi maa sahakam
- C. Doli ba gora
- D. Tahimi bɛ zuɣu sahakam

PAPER 2
ESSAY

Piimi tuma ɗo puuri xayyini n–sabi ki Kamari bachi kobiga ni pihimu ɗfɛ laasabu

1. A daa piila zo palo yi shikuriti diɗma ni yiɗijem laɗringu shɛli din daa yoli niɗ la Sabimi washiika ti o, nyɛrio ani daa wum di nyayisim shɛm.
2. Buɗim wuhi a ni duɗiɗi a bindiri yur–li shɛm
3. Asibiridalikam a nyɛla ɗun zori ginda asibaas sabimi wutii din che ka a zori gindi maa.
4. Ghana puuni behigu mini tinduya ni behigu, dini–n lee so dikpee?

COMPREHENSION

Karimmi kariɗ din doya ɗo ka labisi bɔhisi ɗan doli li maa zaa.

Doo mini o paɗa n–daa be tiɗkpaɗ shɛli yuli booni Bankani. Be daa dɔɗila bipuɗirisi ayi Adamu mini Minatu. Bihi ɗo ba daa kpimi ka be na bi pɔbigi na. Be ba ni kpi di ti yen gili yuuni ka be ma gba kani.

Be ma ni daa yen kani, oo daa bolila Adamu n–ti yɛli o n–ka alaafɛe, ka tishiri ni n–nyɛla ɗun ni tabigi bokati. Dizuxu n–chela Minaatu niɗ a nuuni. Lihimi o zuɗu vienyɛla. O yi ti bi paɗa, nyin zaɗmi o ti dooso ɗun nyɛ asazanira. O yi ti dɔɗi bihi nyin lihim ba vienyɛla. Zaɛrni arizichi shɛli n–ni che n–zaliya maa lihi ba.

Adamu daa saɗiya ni oni tum o ma ni ouhi o tuunshɛɗa maa zaa. Chɗu dali daa ti paa: ka Ada,I zaɗ Salima nyingokoliga maa ti Minaatu ka o ye. Nyingokoliga maa daa ta bɔrigimi.

Questions

- a. Bihi al aka doo maa mini o mala?
- b. Saha dini ka bihi maa daa kɔɗ be ba ru ma?
- c. Be yi yɛli tabigi bokati, bɔ ka di wuhi?
- d. Lihimi yihi yeltɔɗinirinli zaɗ yini Sabibu maa Puuni
- e. A lee tishi ni bɔzuɗu ka be madaa che Minatu niɗ Adamu nuuni?
- f. Litircha biɛlim dini n–lee nyɛ zaɗmi o ti doo?
- g. Bɔzuɗu ka Adamu daa zaɗ nyingokoliga la ti Minatu.
- h. Wula ka di daa niɗ ka nyingokoliga maa ti bɔrig.
- i. A lee tishiya ni behigu bɔ n–lee yen be, bihi ɗo Sunsuuni nyingokoliga ɗo bɔrigimu nyaanɗa?
- j. Bomi yuli n–ti kariɗ ɗo. Di che ka di bachi nim yaɗi dibaayopɔin.

TRANSLATION

Lebigimi sabbu ɲɔ zaa Dagbanli ni

- a. The students were rewarded for their performance.
- b. I saw a snake in the bush on my way to school.
- c. It rained heavily this morning.
- d. The teacher is very thirsty.
- e. The harmattan is very severe this year.
- f. Who came here yesterday?
- g. You must be careful on the road.
- h. Kofi ate all the food on the table.
- i. The black cat jumped over the wall.
- j. Why do people cheat others so much in this country?

LANGUAGE AND USAGE

Sabimi bachipubu sheɲa din gbuna ni booi booi yeltɔɣa din sabidoya ɲɔ zaa ni.

- a. Paɣa ɲɔ viɛli pam
- b. Doo ɲɔ mini o paɣa sa gomi sɔhala

Aabi sabi ɲambɔɔ visnyɛla

- c. Yeltɔɣili puuni yi mali bachiniɲdili zaɣ' yini di nyɛla...
- d. Veltɔɣili bɔ n tec bɔɲɔ?
O bi chaɲ school dama o biɲrimi?
- e. Sabimi yɲltɔɣi wɔɣinli sɔɲ.
Yɲltɔɣiwɔɣinli malila kulo zaɣ yini.....
Kulor nima.

EUE
PAPER I
OBJECTIVES
10 MARKS

Tia ɲuɖoɖo si aso la na biabia siawo

1. ɲuɖoɖo siawo dometo kae wotsɔ na kpene de tabianuwo ɲu le srɔdeɖe me?
 - A. Akuta
 - B. Nuɖugba
 - C. Zikpui
 - D. Fedenu

2. Wona siawo dometo kae ana be atsugbegbe nava la srɔdeɖe me?
 - A. Srɔɲutsu fe dowoɔ na toa
 - B. Srɔɲutsu fe gakpɔkpɔ
 - C. Xo ga siwo le srɔɲutsu si
 - D. Srɔɲutsu fe ahatsunonɔj

3. Wona kae wowona nenye be wodi be woade foa le zi dzi?
 - A. Woko ne de apake me
 - B. Woko ne de tu dzi
 - C. Wodena afɔkpa le afɔ ne
 - D. Wozia ha ne

4. Hlo kawoe ooa tsi di le Anloawo fe azadufe?
 - A. Adzoviawo
 - B. Bluawo
 - C. Bateawo
 - D. Lɔafeawo

LISTENING AND SPEAKING
10 MARKS

Tia ɲuɖuɖu si aso la na biabia siawo

5. Nukoko nenie wo nya sia – “ahanomunoto”.
 - A. f
 - B. v
 - C. o
 - D. x

6. Tò asi gbekòkò dzesi dzi le gbedìdì siawo dome.
 A. \
 B. /
 C. –
 D. V
7. Gbedìdì fòkpli siawo dometò kae mewuna nya nu le Euegbe me o.
 A. gbe
 B. tsy
 C. ee
 D. ie
8. Ablòdegbedìdì nenie le Euegbe me?
 A. f
 B. ɔ
 C. x
 D. d

PART 3
ORAL LITERATURE
10 MARKS

Wu lododo siawo nu:

9. Avu medzia vi ðe le.....o.
 A. Dume
 B. Dugodo
 C. Dutofo
 D. Duxa
10. Avi meḡina le duta.....o.
 A. Wofa nu
 B. Wobia dzi
 C. Wokoa nu
 D. Wofua x̄e
11. Ha ka fomevie wodzina le kutefewo.
 A. Avihs
 B. Dzidzoha

- C. Xoseha
 - D. devime ha
12. Kɔnu kae Aklɔbɔwo wɔna heɔea nyɔnuvi fe tsitsi fianae?
- A. Gbɔto
 - B. Dipo
 - C. Bragrɔ
 - D. Afā

PART 4
WRITTEN LITERATURE
10 MARKS

Xlɛ nyadu sia eye naɔɔ biabia siwo kplɔe ɔo la ŋu
Esi medo goɔe ŋutsuvi eveawo fe avaiwɔwɔ nu la, mewɔ ɔe sia be male avua le wo dome. Ke mekpɔ be nye ŋusɛ mede wo tɔ nu o. Deka wɔ avu alegbegbe abe dzata ene. Elɛ nɔvia fu anyi hefoe vevie vevi. Vu gbā blae. Mese veve ɔe wɔna sia ŋu, Dzrewɔla eve siawo tso fome ɔeka me. Kpatogui, ame si fo nɔvia, Agbenyo vevie la medi ba yeadzudɔ avua o. Le efe nya nu la, Agbenyo fi yefe ga home aɔe. Mlɔeba la, medze agbagba he ŋutifafa va wo domee. Mena wonya be ame ɔeɔe melena lā agbalɛ vuvuna le eŋu o, eya ta madi be woawɔ ɔeka abe nɔviwo ene. Wo ame eveawo se wo nɔewo gɔme eye woakaka yi afe.

Bibiabiawo

13. Nuwɔla eve siawo dometɔ kae nye nuwɔla gā le nyadua me?
- A. Agbenyo
 - B. Kpatogui
 - C. Dzrewɔla
 - D. Nuŋlɔla
14. Gbedanɔ ka fomevie nye wɔ avu alegbegbe abe dzata ene”.
- A. Metaphor
 - B. Gbetɔdonu
 - C. Simile
 - D. Biabia
15. Seselelāme kae nuŋlɔla ɔe fiā le nyadua me?
- A. Dzidzɔkpɔkpɔ
 - B. Avifafa

C. Vevesese

D. Konyifafa

PAPER 2
PART I
COMPOSITION
30 MARKS

1. Tso nyadu, si manɔ kpuie wu nyarɔlɔ ɛfɛ o la ɔ nyati siwo gbɔna la dometo ɔka ko te.
 - a. Ɖdze xɔlɔ yeye aɔ le sukuwo fe abofofo fe wɔna siwo yi dzi miafe suku me la. Ɔlɔ agbalɛ nɛ eye nàgbɔ ale si wɔnawo do dzidzɔ na wɔe la ŋu.
 - b. Do ale si woɔaa nuɔɔɔ si nɛlɔ vevie lae.
 - c. Mevona le memlidagbe ŋdiwo o. Gblɔ nu siwo nɛwɔna siwo nana be mete ŋu vona o la.
 - d. Ɔo nu tso nu si ta mɛdi be yeawɔ ablotsi alo Ghana o la ŋu.

PART II
COMPREHENSION
10 MARKS

Xlɛ ŋutinya si gbɔna la eye nàɔ biabia siwo kata kploe ɔ la ŋu.

Ɔutsu aɔ kple srɔa nɔ kɔfe aɔ si woyɔna ba Srɔgboe la me gbe ɔka. Vi nyɔnuvi eve nɔ wo si. Wofe ŋkɔwoe nye Koenya kple Esinu. Wo fofu ku esime wole ɔvi me. Le fe ɔka megbe tututu la, wo dada hã ku le wo gbɔ.

Ke hafi wo dada naku la, eyɔ Koenya va eɔkui gbɔ le efe ɔbadzi hagblɔ nɛ be “mele ɔ lɛm vevie eye menya be matrɔ megbe, eya ta mede Esinu asi na wobe nàkpɔ edzi nyuie. Nyenye be wɔtsi la, ɔ asi eŋuti na ŋutsu si si agbe nyuie le be wɔaɔee. Nenyɛ be edzi vi la, lɛ be nɛ kple viawo. Tso viawo abe wo ŋutɔ tɔ ene eye nàché wo ɔ kato. Zã nye nunɔamesiwo kata kpe ɔ esiwo megblɛ ɔ la na wɔe le wo hehe meƆ

Koenya do ŋugbe be yeawɔ ɔ dzi abe ale si wɔgbɔe la ene. Le ŋugbedodo si wɔwɔ na dada ta la, elɛ be na nɔvia nyuie ba se ɔ gbe sig be wofe deza ɔɔɔ ɔ dzile wofe kɔfea me. Koenya tso efe sikakɔga na Esinu be wɔaza le azã la me. Ke dzɔgbevɔetze la, kɔga la bu.

Biabiawo

- a. Vi nenie le srɔtɔ eveawo si?
- b. Xe ka xie dzilawo ku le ɔviawo gbɔ?
- c. Nya sia gɔme ɔ? “trɔ megbe”
- d. De dzesi adagana ɔla le nunɔɔɔ me.

- e. Nu ka tae n̄esusu be wo dada gbl̄e Esinu ɔe Koenya si me ɔo?
- f. Gbed̄aŋu kae nye “di asi na ŋutsu si be yeaɔi la?”
- g. Nu ka tae Koenya ts̄o k̄oga la na Esinu ɔo?
- h. Aleke w̄o hafi k̄oga la bu?
- i. Nu ka nesusu be age ɔe Koenya kple Esinu dome le k̄oga la fe bubu ta?
- j. Di Tanya si mawu nya xexleme adr̄e na ŌãĔ nyanl̄oɔi la.

PART III
LANGUAGE AND USAGE

10 MARKS

Ŋl̄o nyaha siwo te fli kpui le la da ɔi

- a. Nȳomu sia dzetugbe.
- b. Ŋustu la kple sr̄o z̄o m̄o ets̄o.

Ŋl̄o ŋuɔoɔo siwo hia la da ɔi

- c. Nyagbe si me d̄w̄nya ɔeka le lae nye.....
- d. Nyagbek̄s̄o ɔeka kple.....foa fu hew̄na nyagbekplanya.

Ɖo giabia siawo ŋu

- e. Nyagbe ka fomevie nye sia? “Meyi saku ets̄o o elabena edze d̄o.
- f. Ŋl̄o nyagbekplanya fe kp̄oɔeŋu ɔeka.

Da gber̄l̄oɔzesi siwo h̄i a la ɔe wo tefe

- g. Efle te, tomatos kple agbitsa
- h. Eɔu nu ŋdi sia

Gbugb̄o nya siawo ŋl̄o ɔe ɔoɔo nyuit̄o nu

- i. Kpaaf̄o.....
- j. Kp̄oɔzidz̄okp̄o

PART IV
TRANSLATION
10 MARKS

Translate the following sentences into your Ghanaian Language.

- a. The students were rewarded for their performance.
- b. I saw a snake in the bush on my way to school.
- c. It rained heavily this morning.
- d. The teacher is very thirsty.
- e. The harmattan is very severe this year.
- f. Who came here yesterday?
- g. You must be careful on the road.
- h. Kofi ate all the food on the table.
- i. The big black cat jumped over the wall.
- j. Why do people cheat others so much in this country?

FANTE
PAPER (OBJECTIVE)
(SAMPLE) (50 MINUTES)
(40 MARKS)

YIYL NSEMBISA NO ANO DE MBRE OSE

1. Ntafo hɔn amona wɔfrɛ no dɛn?
 - A. Kakra
 - B. Tawia
 - C. Abam
 - D. Nyankomago

2. Nhwɛhwɛmu a akanfo yɛ ansaana egya ekebisa awar ama ne ba banyan

 - A. Mpaekyir
 - B. Abowmubɔdze
 - C. Tambobaa
 - D. Ehyiadze

3. Eɓɛn Akan ebusau na hɔn ahyɛnsew nye seɔ?
 - A. Nsɔna
 - B. Twidan
 - C. Anɔna
 - D. Kɔna

4. Iyinom mu woana na oyi mpaa ansaana woato ɔhen fofor dzin?
 - A. ɔhenbaa
 - B. Gyaasehen
 - C. Annkɔbeahen
 - D. Nkonguahen

5. Eɓɛn kasafua anaa akyerɛwamba na ibotum dze asɔw dɛm kasafua yi do
 ma oedi mu anaa ntseasee aba mu ri.....?
 - A. nom
 - B. su
 - C. dzi
 - D. saw

6. Ndze ngyegyee ahorow ahen na yehu no wɔ kasafua “akyerɛwamba” mu?
- esia
 - ebiasa
 - anan
 - kor
7. Kasafua “mobɔnom” wɔ kasafua nkyekyɛmu ahen?
- kor
 - ebien
 - esoun
 - ebiasa
8. Kyerɛ iyi ase, “ɔaka nkyen egu”.
- obi ewu
 - obi awo
 - obi edzi ewu
 - obi ridzidzi
9. Sɛ edze kokrobetsir kɔ eyi a, wɔdze
- abatsir gya wo kwan
 - sotɔr gya wo kwan
 - nsakɔn gya wo kwan
10. Eɓɛn mber na obi tow dɛm ndwom yi “woana ne ba nyi, egya Kwesi ba a”?
- ber a abofra ada
 - ber a abofra rusu
 - ber a abofra reserew
 - ber a awo abofra no
11. Ndwom a wɔtow no wɔ anansesɛm mu wɔfrɛ no dɛn?
- Egyinatu
 - Nsesaawa
 - Ntentan
 - Nbogu

KENKAN DZA OTOA DO YI YIE NA YIYI NSEMBISA A ODZIDZI DO ANO
MA ONYE FEW

Mensah kyer no bɔ n'akoko. Dza akaa nye de yebɔhwɛ no do yie. Yɛbɛyɛ buw kakraba bi dze no ato mu ma oenyin. Mensah nye ne nyenko fofr yi too anomabuw mu, maa no nsunsuma ma odzii. Dem anoma yi nyiin fɛfɛfɛfɛw yɛɛ ne ndzɛmba nyinara de no wura. Sandra bɛyɛɛ Mensah ne nyenko bɛɛbo.

Otum nye no dzi nkɔmbɔ. Mensah siesie hɔn dan no ekyir duaa nhyiren fɛfɛfɛw wɔ hɔ na ɔdze hɔ yɛɛ Sandra ne fie.

12. Eben tsir asem na ibotum dze ama dza akenkan yi?

- A. Yendodɔ hɛn ho
- B. Oɔɔ nnyɛ adzɛpa
- C. Fa abotar tsena
- D. Hom mma yendzi nokwar

13. "Yɛɛ ne ndzɛmba de no wura" yɛ ebenadze wɔ dza akenkan yi mu?

- A. Gyina hɔ ma
- B. Sɛ nyimpa
- C. Ntoto ho
- D. Kasapruw

14. Akenkansɛm yi fa woana ho paa?

- A. anomabuw ho
- B. Mensah ho
- C. Sandra ho
- D. Nsunsuma ho

15. "Sandra bɛyɛɛ Mensah ne nyenko bɛɛbo" kyɛɛɛ dɛn wɔ akenkan yi my?

- A. Gyina hɔ ma
- B. Kasa
- C. Ntoto ho
- D. Sɛ nyimpa

FANTE PAPER 2 – 1 HOUR 10 MINUTES
(60 MARKS)

This paper consists of four parts: I, II, III and IV. Answer only one question in Part I and all the questions in Parts II, III and IV.

(PART I)
COMPOSITION
(30 MARKS)

1. Fa nkasafua bɛyɛ ɔha eduonum Ōɛfɛɛ kyɛrɛ dza ɔka do yi mu kor ho asem.
 - a. Inya nyɛnko bi ber a skuul agodzi akansi kɔr do. Kyerɛw krataa kɛma wo nyɛnko no, na kyɛrɛ mbrɛ oenyi sii gyee kyɛrɛ no.
 - b. Kyɛrɛ mbrɛ wosi yɛ edziban a epɛ paa.
 - c. Memenda anopa biara nkorɔfo hu dɛ iridzi dwuma pii. Kyerɛkyerɛ mu ma wo nysnko, dwumadzi biara a; idzi no wɔ dɛm ber no mu.
 - d. Hemfa na epɛ dɛ etsena, Ghanaman mu anaa aborɔkyirman mu?

(PART II)
COMPREHENSION
(10 MARKS)

Kenkan nsɛm a ɔka do yin a yi yi nsɛmbisa a ɔwɔ ase no nyinara ano.

Banyan bi na ne yer tsenaa ekurase bi a wɔfrɛ no Hwɛ Bi Na Kɔ. Nna wɔwɔ mbabaa beenu a hɔn edzin dze Afrakuma na Boatemaa. Hɔn papa wuu ber a wosuar nna hɔn maame nso wuu afe kor ekyir a papa no dze wui.

Maame no yarba mu no, ɔfrɛ Afrakuma na ɔkaa dɛ “muhu dɛ mɔbɔhwɛr mo nkwa”, dɛm ntsi medze Boatemaa hyɛ wo nsa, hwɛ no do yie. Sɛ onyin a, ma banyan papa mpaa no abanyɛn. Hwɛ ne mba yie dɛ woara wo dze. Fa dza mo wɔ nyinara hwɛ mbofra no nyinara yie.

Afrakuma bɔ mbɔdzen yɛ dɛ mbrɛ ɔhyɛ bɔ no pɛpɛpɛr, boa no nua basia no kɛpɛm dɛ mber a woridzi hɔn afahyɛ no, Boatemaa yeew egudzi a Afrakuma dze maa no dɛ ɔmfa nsiesie no ho no.

- a. Mbofra ahen na awarfo no wɔ?
- b. Mbɛn mber na awofo no wui?
- c. “Mobɔhwer mo nkwa” asekyerɛ nye dɛn wɔ akenkan no mu?
- d. Kyerɛ kasambirenyi kor a ɔwɔ akenkan yi my.
- e. Eɛnadze ntsi na Boatemaa ne maame dze no hwɛ Afrakuma nsa?
- f. “Mpaa no abanyɛn” yɛ eɛn kasa?
- g. Eɛnadze ntsi na Afrakuma dze eguadze no maa Boatemaa?
- h. Ɔyɛ dɛn na egudze no yewee?
- i. Eɛn nkitakodzi na ehwɛ a ɔbɛba enuanom beenu no ntamu ber a egudzi no yew no?
- j. Fa nkasafua a ɔmmbor esuon to akenkansɛm yi dzin.

(PART IV)
LANGUAGE AND USAGE
(10 MARKS)

YIYL NSEMBISA A ƆWƆ ƆFA YI NYINA ANƆ

Kyerɛw KASAKUIN a nkasafua a woetwitwa ase yi wɔ mu.

- a. Dɛm maame yi ho yɛ fɛw.
- b. Banyin no na ne yer tuu kwan ndeda.

Fa dza odzi mu sosɔw asɛntɔw biara do ma onwie yie.

- c. Asɛntɔw a nyɛ kor pɛr wɔ mu no wɔfrɛ no dɛn?.....
- d. Eɛnadze nye Asɛntɔw Tsentsɛn?.....
Ɔyɛ asɛntɔw a ɔwɔ asempruw tsir na
- e. “Basiaba no annkɔ skuul osiandɛ ɔyar”. Eɛn asɛntɔw nye yi?.....
- f. Kyerɛw asɛntɔw kor a ɔyɛ asɛntɔw tsentsɛn

Fa kasa mpaapaamudze toto iyinom ho ma ondzi mu.

- g. Basiaba no kɔtɔw bayer tomantese na ntorɔba wɔ guamu.
- h. Idzii edziban bi anapa yi

Kyerɛw dɛm nkasafua yi a odzidzi do yi yie.

- i. engiyey
- j. mpoaba

GA
PAPER I
OBJECTIVE TEST

Sane fɛɛ sane ni abi lɛ, ekɛ hetoi srɔtoi ejwɛ nyiɛ, ni akadi hetoi nɛɛ A,B,C,D. Shi be fɛɛ be lɛ, hetoi ejwɛ lɛ atɛɛ ekome pɛ ji nɔ ni ja. Taomɔ hetoo ni ja lɛ, koni no sɛɛ lɛ okɛ pensil adiki adeka ni kɛ hetoo lɛ kadimɔ lɛ yaa lɛ mli lɛ saji ahetoohamɔ wolo lɛ nɔ. Okadidi adekai enyɔ amlɛ kɔkɔkɔ kɛha sane kome hetoo. Naa nɔkwɛmɔnɔ:

Gbei kome ni akɛhaa maɲo kɛ akutu kɛ akpakpa ji

- A. Yibii
- B. Niyenii
- C. Aduawai
- D. Tso nɔ niyenii

Hetoo ni ja lɛ ji aduawai no hewɔ lɛ adiki C adeka lɛg
ũAɜ ũBɜ ũCɜ ũDɜ

Gbee wiemɔmuji lɛ atɛɲ eko fɛɛ eko naa kɛ hetoo ni ja fe fɛɛ.

1. Ashwieɔ klaɲ dani abuwɔ.....fɔ.
 - A. jata
 - B. abletsi
 - C. gbee
 - D. shwuɔ
2. Kooloi fɛɛ atɛɲ nilelɔ yɛ adwsatamɔ mli ji.....
 - A. Aduɲ
 - B. Wuɔ nuu
 - C. Akroma
 - D. Anaanu
3. Adole nine kɔlɔɔ shi. Enɛ tsɔɔ akɛ Adole.....
 - A. Juɔ
 - B. Sumɔɔ niyenii
 - C. Niji kɛlɛ
 - D. Kɔlɔɔ nibii yɛ shipɔɲ

4. Yε Gamsi asatsɛj lɛ, kaka ni alaa kɛwɔlev abifao lɛ eko ji.....
 - A. Namɔ ye lɛ awui
 - B. Meele ni yaa eei
 - C. Beebi kaafɔ
 - D. Yeeyeye

5. Gbsi kui srɔtoi.....fɛɔ Gamsi agbsi kui lɛ.
 - A. Ejwɛ
 - B. Enumɔ
 - C. Ekpa
 - D. Kpawo

6. Gbsi haa anaa nibii nɛɛ fɛɛ bɛja
 - A. Maŋ nɔ ni ojɛ
 - B. Nanemsi ni oyɔɔ
 - C. Tso ni wo bo
 - D. Weku mli ni ojɛ

7. Kwashi Obodai gbsi lɛ tsɔɔ akɛ afɔ lɛ.....
 - A. Soo
 - B. Sohaa
 - C. Hɔɔ
 - D. Hɔgbaa

8. Mɔ ni kɛ maŋtɛ tsɔɔ maŋbii yɛ maŋ jara nɔ ji.....
 - A. Akwaashɔŋtɛ
 - B. Jaasetɛ
 - C. Otsaamɛ
 - D. Shipi

9. Anaa weku tɔkpai nɛɛ fɛɛ yɛ Ga Mashi bɛja.....
 - A. Gbese
 - B. Lɛŋshi
 - C. Otublohum
 - D. Sempe

10. “Niyénii”: yɛ wiemɔkuli nɛɛ mli lɛ, mɛɛ gbee ni ka blawa ni afo shishi lɛ nɔ?
- A. Gbee ni yaa ŋwɛi
 - B. Gbee ni baa shi
 - C. Gbee ni ka tɛŋ
 - D. Gbee kaaa nɔ
11. Blawai enyɛɛ ni yɔɔ wiemɔkuli nɛɛ mli ũtsakemɔɔ?
- A. Ekome
 - B. Enyɔ
 - C. Etɛ
 - D. Ejwɛ

Kanemɔ adesa kuku nɛɛ koni ohahai sanebimɔi ni nyɛ sɛɛ lɛ aheto.

Ju leebi ko yɛ Manyawale nyɔɔŋ lɛ mli yɛ afii ... mli lɛ, anu ni Ga yei miibo, “Eŋmɔŋ oo.... Belɛ nɛkɛ amɛkɛfoɔ shi yɛ Mashi niaŋ.

Nii Ama bi Ayikuma na miishɛɛ. Miishɛɛ lɛ ha ehɛ je ehe nɔ akɛ ebaayaa sukuu. Etee ŋshɔ lɛ naa. Mo mli lɛ, ŋshɔ lɛ naa eemɛ etsemɛi alɛlɛ lɛ.

Be saŋŋ sɛɛ lɛ, etsemɛi bakpleke kɛ loo lɛlɛ obɔ. Nɛkɛ gbu nɛɛ lɛ, onuɔ ni loo miila, belɛ nɛkɛ ni ŋŋŋI kɛ dodompoi shiɔ akan.

Nii Ama na ebiinuu lɛ yɛ ŋshɔ lɛ naa. Ewo foi kɛyi ebinuu lɛ sɛɛ. Ama yi shi tamɔ wɔŋtɛ be ni ena ebinuu lɛ. Emɔ lɛ ni eyi lɛ waa. Ayikuma kɛ yaafɔ tee shia ni etswa efai shi akɛ, eban ŋshɔ lɛ naa dɔŋŋ ejaakɛ etɛɛ ewo lɛ sukuu. Ayikuma kpa ŋshɔ lɛ naa yaa kɛyashi egbe sukuu naa.

Haa sanebimɔi nɛɛ aheto

12. Oti ni yɔɔ adesa ni okabe lɛ mli lɛ ji.....
- A. Heshibaa
 - B. Anɔkwayeli
 - C. Toiboo
 - D. Wuoyaa
13. Namɔ ji shwsbilɔ oti
- A. Ayikuma
 - B. Loo
 - C. Lɛlɛ
 - D. Nii Ama

14. Te wiemɔmuji nɛɛ atɛŋ nɔ ni ji ookɛɛgbɔmɔ?
- A. Loo miila, beɛ nɛkɛ ŋŋoi kɛ dodompɔi shiɔ akan
 - B. ɔshɔ lɛ naa eyɛ sakoo damɔ sinoo
 - C. Ayikuma kpa ɔshɔ lɛ naa baa
 - D. Yei miibo eŋmɔŋ oo eŋmɔŋ oo
15. Mɛɛ wiemɔ heŋɔmɔwolɔ i akɛtsu nii yɛ wiemɔmuu nɛɛ mli “eyɛ sakoo tamɔ sinoo”.
- A. No–ni
 - B. Tamɔ–no
 - C. Ookɛɛgbɔmɔ
 - D. Gbɛigbɛɛɔ

PAPER 2
PART I
COMPOSITION (30 MARKS)

Ha sanebimɔi nɛɛ atɛŋ ekome pɛ hetoo. Esa akɛ onirɔmaa lɛ ashɛ wiemɔ kuli bii ɛfɛ.

1. Ɔɔmaa wolo oyaha onaanyo hee yɛ sukuu kroko ni ogba lɛ shwɛmɔ akaŋshii koo ni oyakwɛ ni ona miishɛɛ he sane.
2. Tsɔɔmɔ bɔ ni ahoɔ niyenii ni onyaa he jobgaŋŋ.
3. Ana abo akɛ mɔ ko ni bɛ deka kwraa daa Hɔɔ leebi. Gbaa otsɔɔ onanemsi nɔ hewɔ ni onaaa deka kwraa lɛ.
4. Gbalamɔ mli otsɔɔ nɔ hewɔ ni obaasumɔ akɛ ohi omaŋ Ghana aloo maŋsɛɛ.

PART II
COMPREHENSION (10 MARKS)

Kanemɔ niŋmaa kuku nɛɛ ni oha sanebimɔi ni nyis sɛɛ lɛ ahetoo.

Nuu ko kɛ ɛŋa hi akrowa ko ni atseɔ lɛ Tetemaŋ. Amɛyɛ biyei enyɔ ni atseɔ amɛ Adole kɛ Adɔkɔ. Nuu nɛɛ gbo trukaa be mli ni gbekɛbii nɛɛ darako kwraa. Afi sɛɛ pɛpɛɛpɛ ni ɛŋa lɛ hu tsɔ esɛɛ.

Dani amɛnyɛ lɛ baagbo lɛ etse Adole ni ekɛɛ lɛ akɛ: “Mibɛ hewalɛ kwraa ni migbeyeishemɔ ji akɛ etsɛŋ ni mashi jɛŋ. Hewɔ lɛ miishi Adɔkɔ miiwo odɛŋ ni okwɛ enɔ oha mi. Kɛji eda lɛ kwɛmɔ ni ena gbala kpakpa ni bii ni ebaafɔ hu lɛ amɛ jogbaŋŋ. Ɔɔ amɛ akɛ bo disŋtsɛ obii ni oha amɛna tsɔsemɔ kpakpa. “Kɛ migboshinii lɛ akwɛ amɛ”.

Adole wo shi akɛ ebaafee bɔ ni enyɛ Awo ekɛɛ lɛ lɛ pɛpɛɛpɛ. Eye eshiwoo lɛ nɔ ni ejie etsui mli kɛkwɛ enyɛmi yoo lɛ keyashi afiyeli gbijurɔ ko bashɛ yɛ amɛkrowa lɛ. Adole kɛ eshika kuɛnii fɛfɛo ko ni eyɔ ha Adɔkɔ kɛha afiyeli lɛ. Ehe ni eyabaaa nii lɛ kuɛni lɛ laaye yɛ gbijurɔyeli lɛ shishi.

Sanebimɔ:

- a. Bii enyis nuu lɛ kɛ ɛŋa lɛ yɔɔ
- b. Mɛsbe fɔlɔi lɛ je mli
- c. Te onuɔ wiemɔ tsɔ esɛɛ shishi tɛŋŋ yŋ yɛ adesa lɛ mli
- d. Ha fɔŋwiemɔ kome ni okɛkpe yɛ aadesa lɛ mli
- e. Mɛni hewɔ osusuɔ akɛ yoo lɛ kɛ Adɔkɔ shi Adole.
- f. Tsɔɔmɔ gbala kpakpa shishi taakɛ bɔ ni akɛtsi nii yɛ niŋmaa lɛ mli.
- g. Mɛni hewɔ Adole kuɛnii lɛ ha Adɔkɔ lɛ.
- h. Te osusuɔ akɛ akɛ nyɛ nyɛmimɛi lɛ atɛŋ sharamɔ baafee tɛŋŋ yɛ kuɛnii lɛ kajemɔ sɛɛ.
- i. Te eba lɛ tɛŋŋ ni kuɛnii lɛ laaje lɛ.
- j. Wo sane ni okane lɛ gbɛi. Ogbɛi lɛ akafa fe wiemɔkulibii kpawo.

PART III
10 MARKS

Tsɔɔmɔ wiemɔmujo nɛ ashishi kɛba Ga kpakpa mli.

- a. The students were rewarded for their performances.
- b. I saw a snake in the bush on my way to school.
- c. It rained heavily this morning.
- d. The teacher is very thirsty.
- e. The harmattan is very severe this year.
- f. Who came here yesterday?
- g. You must be careful on the road.
- h. Kofi ate all the food on the table.
- i. The big black cat jumped over the wall.
- j. Why do people cheat others so much in this country?

PART IV
LANGUAGE AND USAGE
10 MARKS

Tsɔɔmɔ wiemɔwɛku mli ni wiemɔ ni afo shishi lɛ yɔɔ.

- a. Yoo nɛ he yɛ fɛɔ.
- b. Nuɔ lɛ kɛ ɛɲa lɛ fa gbɛ nyɛ.

Gbee wiemɔmuji nɛ anaa

- c. Atsɛɔ wiemɔmuu ni hiɛ Feemɔwiemɔ kome akɛ.....
- d. Mɛɛ wiemɔmuu hɛɲɔ ji: **Eyaa sukuu ejaake ebɛ hewalɛ.**
- e. Ha wiemɔmuu haɲtsii hiɛ sanefa oti kome kɛ sanefai.....
- f. Wiemɔmuu haɲtsii hiɛ sanefa oti kome kɛ sanefai.....

Kɛ niɲmaa mli okadii ni ja awo hei ni sa yɛ wiemɔmuji nɛ amlɛ koni amɛye emuu.

- g. Ehe yɛlɛ, amɛo kɛ sɛbɛ.
- h. Ani oye nɔ ko leebi nɛɛ.

Saamɔ oɲmala wiemɔkulibii nɛ jogbaɲɲ

- i. Hɛmsisi
- j. Pasareeta

GONJA
PAPER 1
OBJECTIVE TEST

Wɔrɔ mbishi ere kike.

Keni A–D to n lara ketuwebi nɛ ku bee tuwe mbishi na.

1. Nganya to, kebia pupɔr be kachɛ fanɛ sepo nɛ baa sa mo ketere?
 - A. burwasepo
 - B. nusepo
 - C. sasepo
 - D. kpanɔsepo

2. Nganya to pɔɛ nɛ enyɛn a kil eche a daga e ka.....
 - A. Kɔ amansherbi
 - B. Sa mo kedampo
 - C. Yili epel
 - D. Ji kasha

3. Baasa mo e naa kii kabuna Ngbanya to?
 - A. Bewura be kanaŋ ebi
 - B. Eyali damata
 - C. Ndetobia nɛ befo
 - D. Mbɔŋwuraama

4. Ade be kumo so nɛ anye kɔ bewura?
 - A. Efuli be kekeniso
 - B. Edemu be kelɔŋɛ
 - C. Eleŋ be keji
 - D. Edaŋkare be kechɛrga

5. Ebolbenchɛrga be akurso ere be kumo ela esosobol?
 - A. ũ\z
 - B. ũ–z
 - C. ũ,z
 - D. ũ/z

6. E p̄r 'laŋ'. Nuso be kurso e daga keyuu 'laŋ' so?
- ũ/Ʒ
 - ũ-Ʒ
 - ũ\Ʒ
 - ũ,Ʒ
7. Mmalgaba ere be kumo e naa yili a sa Ngbanya be Kamalgakul be kap̄r 'KEK'?
- ebu
 - p̄r
 - mbɛ
 - klaŋ
8. Ade be kumo ela keŋaga?
- Afuu bee foŋ kafoli
 - E bee d̄ɔ fobe md̄ɔto
 - B̄mbɔŋɛ be mpirgi, a beeŋ kaŋ ba
 - E kp̄oŋ n kaa sha kdu fanɛ j̄ɔnɔ bompo
9. Nuso be ngbar be kep̄rso ela kede? "mbombi bee t̄r nchu to".
- Ketankiesa
 - Kamalgatr̄mbi
 - Kamalgak̄nto
 - Ketankargaso
10. 'Ma kesh̄rkapaŋ nde,' nuso nɛ baa shuliso?
- Awo
 - Ku wale
 - Kelamba
 - Ayɛso
11. N̄hɛ lulombia be tunɔ ko n sa enio ela fanɛ e beeŋ nyɛ.....
- Ajibi n ji
 - N ya dese n wushi
 - B̄r kebia na
 - Jimans̄ n shuŋ

Kraŋ kebɔaya ere n shin wɔrɔ mbishi nɛ a bɛso na kiki. Ewura ko nɛ bu daa tere Gbɛadese. E da kɔ beche anyɔ, Edoŋbɔnɛ nɛ Echintir. Edoŋbɔnɛ e daa la mobe kenishi nkpal mobe kebita nɛ da lɛla so. Echintir bre daŋ bɔni nna a kɔ ntol fanɛ luku. E daŋ kpoŋ ere da maa nyɔ abar edɛ. Bumobe kolu daa yilso karechɛnkama nna. Kachako, Wurpe nɛ Gbɛadese ka ddese ebu to, jimanɛ nɛ edi chulwi waje m buu kade na, nɛ e bir mo so ntiŋi. Bumobe kelejima to nɛ e kuu efɛ damta n deŋI Edoŋbɔnɛ.

12. Keshɛrkpaŋ ere be keshɛrtirso ela.....
- A. Kakil be asheŋ
 - B. Gbɛadese be elenji
 - C. Echintir nɛ mo chamana
 - D. Beche be kolu
13. Wansɛ ela keshɛrkpaŋ ere be epɛlpo nimuso?
- A. Echintir
 - B. Edoŋbɔnɛ
 - C. Gbɛadese
 - D. Bumo kiki
14. Ade be kumo ela kudulibi kebɔaya na to?
- A. Daa la mobe kenishi
 - B. Da maa nyɔ abar edɛ
 - C. Kolu da yilso nna karechɛ kama
 - D. A sha kolu fanɛ jɔnɔ bompo
15. Edi chulwi waje m buu kade la.....nna.
- A. Ketankiesa
 - B. Keŋasa
 - C. Kamalgakɔnto
 - D. Kamalgaatrɔmbi

PAPER 2
PART I
COMPOSITION
30 MARKS

Sibɛ kasibɛbirabarso nɛ amu ere be kekoɲwule nɛ fobe mmalgaba e fo kafa nɛ adenu ɛfɛ.

1. Fo nɛ ɛteri pupɔr ashi menyɛbe asukuru be kechala m pel n chaɲɛ abar monɛ ku choɛ na to. Sibɛ kawol n ya sa mo a kute kananɛ epelana na wɔrɔ fo ebel.
2. Delgeso kananɛ baa daɲɛ fobe ajibi shaso.
3. Ba kaa wu fo nɛ fobe kenishi pre a wɔrɔ asɔ ko Asibitiachɛ kama be kachipurso. Ɖjinito asɔ nɛ a bee shins fo wɔ loɲ be kebawɔtɔ to n sa fo teriana.
4. Ta kamɔrɔji n ɲini to asɔ mo so nɛ feɛɲ baa sha kebaa wɔ Ghana to nko Mbronito.

PART II
COMPREHENSION
10 MARKS

Kraɲ kebɔaya na kike nɛnɛ n shin wɔrɔ mbishi nɛ a bɛso na kike.

Kanyɛn ko nɛ mobe eche e daa wɔ kulpe. Bu daɲ kurwe mbichesobi benɔ, Afiima nɛ Bimunka. Bu kra maɲ daɲ kpoɲto nɛnɛ nɛ bumo tuto wu. Bumo tuto ka wu, kafe nɛ ya bɔ m ba, nɛ bumo nio malɛ wu.

Ama, pɛ nɛ bumo nio e wu, e tere Afiima m ba mobe gado ase n shin kaɲɛ, Mee lo ga nɛ a bee wɔrɔ ma fanɛ meɛɲ ee lo ga nɛ a bee wɔrɔ ma fanɛ meɛɲ ta kato n gbasa. Amoso, mee yige Bimunka a wɔtɔ fobe enɔ to. Keni mo so nɛnɛ. E kaɲ ba daɲ, ta mo n sa enyɛn pa. E kaɲ b aka nɛ abatobi, keni mo nɛ mobe mbia so nɛnɛ. Ta mobe mbia fanɛ fo gbagba peya n shin bla bumo nɛnɛ. Ta keshɛ kama nɛ n ko nɛ keshɛ kama nɛ mee yige a sa fo na n keni bumo. Afiima sa kɔnɔ monɛ e beer wɔrɔ kanamɛ e kaɲɛ mo na. Nkpal kɔnɔ monɛ e sa mo nio na so, e keni mo sipo so nɛnɛ m baa fo bumobe kachɛgboɲ ko be kachɛ. Afiima ta mobe shuwa be kubɔto shembi n sa Bimunka. Kubɔ to shembi na foe epel to.

- a. Mbia afanɛ nɛ kanyɛn na nɛ mobe eche kurwe?
- b. Jimanɛ mo nɛ mbia na paɲ bumo nawuraana?
- c. Manɛ ela kamalga ere, “ta kato n gbasa”, be kefiito kananɛ ku wɔ kebɔaya na to.
- d. Lara efuli kamalgaɲmɛ koɲwule kebɔaya na to.
- e. Manɛ so nɛ fo tama fanɛ enio na yige Bimunko n wɔtɔ Afiima be enɔ to?
- f. Manɛ be ngbar be kepoɲsobi ela, ‘kaɲ b aka nɛ abatobi’?

- g. Manε so nε Afiima ta kuboto shembi na n sa Bimunka?
- h. Nsuo nε kuboto shembi na wɔrɔ m foe?
- i. Nsuo nε fo tama mbia na be kefiato beenj ba du keshembi na be kefoe be Kaman?
- j. Ta mmalgaba ashunu n sa keɔaya na kumu dagaso.

PAPER III
TRANSLATION

Kilgi mmalgafol ere n yɔ Nganyato

- a. The students were rewarded for their performance.
- b. I saw a snake in the bush on my way to school.
- c. It rained heavily this morning.
- d. The teacher is very thirsty.
- e. The harmattan is very severe this year.
- f. Who came here yesterday?
- g. You must be careful on the road.
- h. Kofi ate all the food on the table.
- i. The black cat jumped over the wall.
- j. Why do people cheat others so much in this country.

PART IV
LANGUAGE AND USAGE

Wɔrɔ mbishi nε a wɔ kaba ere to kiks

Sibε mmalgaba nε amobe nseto chaɲ na be katuj

- A. Kache ere walε kebita
- B. Kanyɛn na nε mobe eche nite ndre

Sa mmalgafol ere be atuwebi

- C. Kamalgafol nε ku kɔ kushuɲso koɲwule ela.....
- D. Kamalgafol milto kɔ kefeltonio koɲwule nε.....

Tuwe mbishi nε a bεso ere.

- E. Nuso be kamalgafol be katuj ela kede?
“E maɲ yɔ sukuru nkpal e ka bee lɔ so”
- F. Sibε kamalgafol milto koɲwule n nase

Ta akurso nε a daga n kur mmalgafol ere

- G. E tɔ ajɔ, kamantosi nε ntre

H. Fo jo ajobi kabre aa

Lọṣe n sibe mmalgaba ere nḡ a niṣi

I. Gbenikafuli

J. Abatasi

**KASEM
PAPER I
OBJECTIVES**

Kuri A–D wone kolo tete na wó wane ko leiri bwia yam lanyerane to.

1. Kasena chulu kolo ba na yeini ba ke se ko bere we busesenja laam ye sɔɔ kom nɔɔno to mo ye bɛ?
 - A. Puga liɔim
 - B. Yere pam
 - C. Kangwoɔa
 - D. Lira zoorem

2. Nɔɔna banto wone, wɔ tete mo yeini o liɔl ka–cheero puga kasoɔo ne?
 - A. Kania
 - B. Nɔɔnkwea
 - C. Bakeira
 - D. Bukɔ

3. Nɔɔna balo na ye nabaaro dedoa to ye bɛ mo daane?
 - A. Chilwonna
 - B. Nagora
 - C. Kadwonna
 - D. Badwonna

4. Pa–chara yeini bap u bɛ mo?
 - A. zonkwɛ
 - B. yupu–seɔa
 - C. yucheiga
 - D. yukwora

5. Doa ná nega, dé.....du mena.
 - A. Wo
 - B. Yaa
 - C. Wó
 - D. Deem

6. Bu wom kana.....wae, o wó di gole dem.
- A. Wo
 - B. Wó
 - C. Na
 - D. Ná
7. Butarebu wɔ yedaa mo ye kvkkvv?
- A. Kagoa
 - B. Kanda
 - C. Memena
 - D. MENCHWA
8. Bu wolo na sane o jea pa se ya gwae to mo ke bɛ?
- A. Di de nakwa
 - B. Di de o bɔla
 - C. Ye bu-lao
 - D. Ye bu-balɔ
9. “Bukɔ wom ni chamma” ye ta-dwi dɔ mo?
- A. Tagungwola
 - B. Memaje
 - C. Toro
 - D. ni-nywoani
10. Sensɔle sɔlem ye lara dwi dɔ mo?
- A. Poponem lara
 - B. Jwoni kaanem
 - C. Ni-lara
 - D. Kwɛra lei
11. Bu gana lei nyɔre dedwe mo ye kɔ tetere?
- A. Se pae bu nia
 - B. Se pae bu keera
 - C. Se pae niina nia
 - D. Se pae bu doa

Ga labaare dem kuri ne to se–n dare n leiri bwia ya, εd–εf ne to.

Amenayere badeim–dwoɲo kom mo swo Manyara bukɔ Anuwora pa se wula zaɲe ka vu logo maama. Ba maa pu jɔɲ pa se ka–dooro wam sa nensene sambilikwola tei. O zembaaro Anɛmaana maa yi jɔɲ kom de sana dedaane sabu. O tage o we o wo pwoli de o nyaane wom kadiri dem.

12. Garem dem nyɔɔne dem tɛ bɛ taane mo?
 - A. Jɔɲ magem
 - B. Kadiri
 - C. Wula
 - D. Zembaaro

13. Wɔ tete mo ye keiru dedɛero wom garem dem wone?
 - A. Anɛmaana
 - B. Zembaaro
 - C. Amenayere
 - D. Anuwora

14. Nonoga taane dɔ mo ye, “wula zaɲe ka vu”?
 - A. Metafɔ
 - B. Simili
 - C. Ka–leiri–ka–ji
 - D. Aleteresem

15. Nonoga taane dɔ mo wo, “sa nensene sambilikwola tei” ne?
 - A. Aleteresem
 - B. Ka–leiri–ka–ji
 - C. Simili
 - D. Metafɔ

PART I
(COMPOSITION)
30 MARKS

1. Kuri bwia yanto wone bween dedwe n ma botarebia na wo muri bi de finnu ŌɛfɛŃ to n popone tapane dem baɲane.
 - a. Nmo nɛ badwoji mo á sikuuli year koresem Kanyerjo kom ne. Popone tɔno n pa-o n maɲe nmo na nɛ kanyerjo kom ywoani tei to n bere-o.
 - b. Maɲa ban a saɲa nmo boboɲa wodi tei to.
 - c. Totoɲa da yaredo / luu dedoa dɛ maama nmo yeini n ye jalemaa mo. Popone n bere kolo de kolo n na yeini nke to.
 - d. Popone n bere kolo ɲwane nmo na wó ta-n lage se n vu feil-teo to naa n na ba-n ta-n lage se n vu to.

PART II
COMPREHENSION (10 MARKS)

2. Ga labaare dem na wo kuri ne to, n dare n leiri bwia yam maama na saɲe to.

Baaro de o kaane deem mo zoore Tanzeka ne. Ba jege bukwa balei mo. Anutua de Kanuga. Ba kwo tege ye ba yaa ta muri mo. Ba kwo na tege bene dedwe maɲa ne to mob a nu de daa tega.

De ko de, se ba nu wom te to, o bwoɲl Anutua mo o peiga jeiga ne ye o we, “Amo tiini a weele mo ye a wae a yage logo. Konto ɲwaane a yage kanuga a pa-m, fɔgɔ-n ni-o lanyerane. O ná bega, pa se o bia taa ye ne n tete bia mo se ba be lanyerane. Ma kolo maama n na jege to dedaane. Ma kolo maama n na jege to dedaane kolo maama a na pɛ-m to n ni ba lanyerane.

Anutua maase se o ke neba nu wom na tage tei to. O maa seene o ni o chorokom lanyerane ko vu ko yi ba teo fao kuri dem dim dɛ ne. Anutua pɛ zɔn-bili mo se o ma o di kuri dem. O maa pa se zɔn-bili dem jei.

- a. Baaro wom de o kaane wom jege bia bagera mo?
- b. Maɲa kɔ mo bia bam gɛ ba tiina?
- c. “Yage logo” kuri mo bɛ ne ko na tu tei garem dem wone to”?
- d. Popone nɔnkwɛ taane dedwe garem dem wone n tiɲi.
- e. Nmo boɲe we bɛɲwaane mo ba nu wom yage Kanuga o pa Anutua to?
- f. Nonoga taane dwi dɔ mo ye se o jeini de baro lao?
- g. Bɛɲwane mo Anutua pɛ zɔn-bili dem Kanuga to?
- h. Zɔn-bili dem ke tɛ mo de jei?

- i. Nmo boje we busankane sem ɲwea deem ye tɛ mo zɔn–bili dem jeim kwaga ne?
- j. Pa garem demy ere kukuanu se ko yé dwoni notarebia barepae.

PART III
TRANSLATION (10 MARKS)

Leiri taana yanto feilim ne se ya vu kasem ne.

- k. The students were rewarded for their performance.
- l. I saw a snake in the bush on my way to school.
- m. It rained heavily this morning.
- n. The teacher is very thirsty.
- o. The harmattan is very severe this year.
- p. Who came here yesterday?
- q. You must be careful on the road.
- r. Kofi ate all the food on the table.
- s. The big black cat jumped over the wall.
- t. Why do people cheat others so much in this country?

PART IV
LANGUAGE AND USAGE (10 MARKS)

Botarebia balo kura na jege bibeiri sem tapuna yam wone to wo botarebia di so wone mo?

- a. Kaane wonto tiini o lamma.
- b. Baaro wom de o kaane wom vei chowɲa diim.

Ma kolo na maɲe to n guri tapuna yanto kuri ne to

- c. Tapuni delo na jege keimbotarebu dedoa yerane to ye.....mo.
- d. Tapun–junjuu jege takuku–dedɛro dedoa mo dedaane.....

Leiri bwia yam kuri ne to de kolo na maɲe to.

- e. Tapuni dwi dɔ mo ye taane dento? “O wo vei sikuuli bɛɲwaane o weele mo”.
- f. Popone tapuni junjuu dedoa n tiɲi.

Jwoori n popone tapuna yanto de ya tɔge popenem wadɛ sem.

- g. O yeigi pia, kamantwoosa de nanjua.
- h. Nmo di wodiw zezeɲa kanto na.
- Fɔge n popone botarebia banto se ba tɔge chowɲa.
- i. Lopwowo.....
- j. Raetan.....

NZEMA
PAPER 1

Fa nyelebenloa A – D anu ne mɔɔ ye edwekemiza ne anloa fɔnwo la.

1. Abusua ne boni a vale nzule nee awule rale a?
 - A. Ezohile
 - B. Nvavile
 - C. Azanwule
 - D. Ndweafɔɔ

2. Saa begya kakula raale a maadee ehye mɔɔ boni a li awielee a?
 - A. Besi ɔ ti asoa
 - B. Bɛbiza ye agyale
 - C. Besie ye aze
 - D. Bedia ye atɔfole

3. Menli ehye mɔɔ boni a bahola ali belemgbunli a?
 - A. Awie mɔɔle sukoavole la.
 - B. Awie mɔɔ le bia now dehele la.
 - C. Sonla mɔɔ ze nwoma kpale la.
 - D. Sonla biala mɔɔ anye ye se la.

4. Duzu ati a Egya Mieza nee ɔ ye donle be ra ne duma ekpote a?
 - A. Be nye die anloma ekpote anwo.
 - B. Ennee bele mota.
 - C. ɔ nee ɔ ye lile abawuo.
 - D. Duma ne ye be fe.

5. “Fɛle Koasi maa me”.
Enele ngyehyelee ohye mɔɔ boni a le fɔnwo wo “fɛle” ebɔle nu a?
 - A. Aze – Aze
 - B. Aze – Anwuma
 - C. Anwuma – Aze
 - D. Anwuma – Anwuma

6. “Me nli p̄le Kuma sua ne anzi”.
- Ènele ngyehyele ehye m̄o boni a le f̄onwo a.
- Kú – mà
 - Kù – mà
 - Kú – má
 - Kù – má
7. Kakula
- Ènelekp̄ke ngyehyele ehye m̄o le f̄onwo la a le boni?
- Kaku – la
 - Ka – ku – la
 - Ka – kula
 - Ka – kul – a
8. “Dwoo dwoo, dwe maa Yaba o”. Meko boni a ereladane bado edwene ehye a?
- Meko m̄o okponde ke o ra ne ale dwe na yeava yeamaa ye la.
 - Meko m̄o nafele eleku o ra ne na okponde ke oda la.
 - Meko m̄o eh̄one eleku o ra ne la.
 - Meko m̄o okponde ke o ra da la.
9. Ohya ke yeto nw̄ora yekile ngakula oboaleke
- Egya ked̄eda duma finde nu.
 - Omaa besukoa adaleb̄ole
 - Otu fole
 - Edweke w̄o nu
10. Dwula erele ehye:
- Be kunlu eleka a
- be nyunlu ende
 - b̄eno ayile
 - b̄esela ayile
 - be nye enlie
11. “Kaku as le bene”. Edweke ehye abo kile ke kaku
- fa o sa bene di ale
 - le awule
 - asa bene ne ye ye nyane
 - bo adale

Kenga adawu ehye na yeye edwemiza ed – ef anloa.

Egya Mozu le eyazonlenli. Befele o ye omo Manza. Be mra a le Adwoba nee Edobele. Kenle ko Fole nwonlomo odwazole la ozile ye nrelande ne omaanle oyale na ke wowole.

Moo odwule ye sya ne anu la obole o bo ke odo ye ndile. Yeangye, anwoma ne bole o bo ke otu na mbaka ne bole be ti aze. Oyale gyima ekyi la ovalel ye etu ne ogyelale na ohole sua zo.

Meks moo odwule sua nu la o ye anye liele kpole.

12. Duzu bodane a adawu ne gyi zo a?

- A. Egya Mozu anwo edweke
- B. Ebonu gyimayele
- C. Adwoba nee Edwoba
- D. Omo Manza anwo edweke

13. Adawu ne nusonla titili ne a le nwane?

- A. Edwoba
- B. Edobele
- C. Omo Manza
- D. Egya Mozu

14. Sonlayele moo wo adawu ne anu la a le

- A. moo odwule ye sya ne anu la
- B. o ye anye liele kpoke
- C. mbaka ne bole be ti aze
- D. ovale ye etu ne ogyielale

15. Edweke “oyale na ke wowole” le

- A. Erere
- B. Edwekenzoho
- C. Edendendenle
- D. Sonlayele

PAPER 2
[60 MARKS]

PART I
COMPOSITION
[30 MARKS]

1. Fa edwemgbokε mɔɔ dwu εfε la kelε ehye mɔ anu ko pε anwo edwekε.
 - a. Kenle nsa ye mɔɔ sukulu ngakyile su nwɔhoalile la enyianle ε gɔnwo fofolε bie. Kelε kelata kɔmaa ye na kile kε ε nye zile liele nwɔhoazulε ne anwo la.
 - b. Kile maa yenwu kε bεsi beto aleε mɔɔ ekulo ye kpale la.
 - c. Folε nwonlomɔ biala enle alagye fee. Kilehile nu maa ε gɔnwo mɔ enwu mɔɔ eyε la.
 - d. Kilehile nu maa yenwu deemoti ekulo kε ekedenka Gana maanle ye anu la anzεε ekedu adenle ekεhɔ maanle gyene zo la.

PART II
COMPREHENSION
[10 MARKS]

2. Kenga adawu ehye nay eye edwekemiza ne mɔɔ doa ye la amuala anloa. Nrenyia bie nee ɔ ye denlanle sua bie mɔɔ befelε ye sendu la azo. Enεe belε bε mra mraale nwio, Mozuma nee Tayiba. Mεkε mɔɔ bε ze wule la εbee bε nye εtεfile. Bε ze wule la ye evolε ko yεε bε nli nook hale εleka bie a.

Kolaa na bε nli awu la, ɔvelεle Mozua wɔ ye ewule ekpa ne anwo ekε na ɔzele ye kε, “Mende kpokε fee na mesulo kε ɔrεhyε me ti babɔ aze. Ehye ati Takyiba wɔ ε sa nu. Nea ye boε maa me. Saa ɔ nye fi a fa nrenyia maa ye. Saa ɔbɔ εdane a maa ε nye εhɔ ngakula ne anwo kpale. Fa ɔ mra ne kε εdawɔ ε mra na tete bε boε. Fa agyapadeε mɔɔ meva megyakyi wɔ la nea bε boε.

Mozuma bole ɔ nli εwokε kε ɔbali mɔɔ yeha la azo. Olua εwokε mɔɔ ɔbole ɔ nli la ati ɔnleanle ɔ diema ne gyelεenye kɔkpula mekε mɔɔ bedi bε εvoyia ne la. Mozuma vale ye ndweabane maanle ɔ diema ne zieziele ɔ now hole εvoyia ne abo.

Moo rale la a le ke ndweabane ne minlinle.

- a. Enee awovole ne amra le nye?
- b. Meka boni a ngakula ne awovole wule a?
- c. Kile “me ti babo aze” abo ke moo behile ye adawu ne anu la.
- d. Ye “edendedenle” ko fi adawu ne anu.
- e. Enea a, duzu ati a, mbelera ne mo be nli vale Tayiba wulale Mozuma asa anu a?
- f. Duzu adwenlenu nvoninli a le “fa nrenyia maa ye”?
- g. Duzu ati a Mozuma vale ye ndweabane maanle Tayiba a?
- h. Ke ndweabane ne zile minlinle e?
- i. Enea a moo ndweabane ne minlinle la ke mediema ne avinli keye e?
- j. Fa edwemgboke moo embo nsuu la to adawu ne duma.

PART IV
LANGUAGE AND USAGE
[10 MARKS]

Kele anesemela abusua moo edwemgboke moo bepe o bo la biala bo la.

- a. Raale ne heda edanle kenlema.
- b. Nrenyia ne nee o ye dule adenle anoma.

Fa nyelebenloa moo le fonwo la so edendemunli ehye mo biala azo.

- c. Befele edendemunli moo le ye kpoke ko la edendemunli
- d. Edendemunli kpomgbondee le edendefo a titili ko ye ngakyile.

Fa nyelebenloa moo le fonwo la ye edwekemiza ehye mo anloa:

- e. Duzu edendemunli a le ehye?
“Yeango sukulu oboaleke onde kpoke”.
- f. Kele edendemunli kpomgbondee ko.

Fa ehale sekelenee wula edendemunli ehye mo biala anu maa oli munli.

- g. Odole elue, tomandese nee ndolera.
- h. Asoo woli ale nwonlomo ye o.

Kele edwemgboke ehye mo maa beli munli.

- i. le nyealie
- j. alamgbobo

TWI (AKUAPEM)
OBJECTIVE PAPER

1. Akwasi papa wui ansa na ne na woo no. Yenetumi afɛ Akwasi sɛ.....
Akwasi sɛ.....
A. Afiriyie
B. Anto
C. Akyerem
D. Damusaa

2. Ansa na ɔbea bi beware no na.....
A. Wagoru no bra
B. Wanyin
C. Wanyinsɛn
D. N'ani ate

3. Papa no yɛ Aduanani enti n'akraboa yɛ.....
A. Kwaakwaadebi
B. ɔsebo
C. ɔkraman
D. ɔkɔre

4. Kofi betumi ayɛ ɔhene efisɛ ofiri.....
A. Ne papa abusua mu
B. Ne sewaa abusua mu
C. Ne nana abusua mu
D. Adehye abusua mu

LISTENING SPEAKING

5. Dɛn na etumi de nsononoe ba asɛmfua mu?
A. ɛnne
B. Kasa
C. Dwom
D. Adesua

6. Ɛnnɛ mmienu ɛwɔ asɛmfua 'kasa' speak mu yɛ soro anaa fam?
 A. Soro
 B. Fam
 C. Soro ne fam
 D. Soro ne soro
7. Asɛm 'ada' wɔ asensini ahe?
 A. Biako
 B. Abien
 C. Abissa
 D. Anan
8. Ɛba yɛ kasasu bi a ɛboa ma kasa tenten yɛ.....
 A. bebree
 B. tiawa
 C. ntease
 D. dɛ
9. Abeawi no ani atra ne ntɔnkyerɛ sɛ.....
 A. obu ade
 B. onim nyansa
 C. ommu ade
 D. n'ani agye
10. Anansesɛm botae titire ne se.....
 A. etu yɛn fo
 B. ɛboa kasatenten
 C. ɛde ntetemu ba
 D. ntease ba
11. Sɛ ɔbeatan reyɛ ade na onya obi gyegye na ba nnwom a, mfaso bɛn na ɛna no nya?
 A. ne ho kyere no
 B. ɛna no nya kwan yɛ nea ɔreyɛ
 C. abogra no susu dodow
 D. ne na no brɛ

WRITTEN LITERATURE*Kenkan nea edi so yi na bua eho nsemmissa no*

Obea bi a na wɔfrɛ no Abena waree na ɔne ne kunu tuu bata. Ansa na ɔrebetu bata no, n'awofo tuu no fo faa aware ne emu nsem ho. Awofo no de to n'adwen mu sɛ, ɛyɛ a ɔnkae sɛ, efie ne fie ɛno nti mma ɔnnyɛ n'ade te sɛ ɔmani wɔ ne batatuw no mu. Ɛsɛ sɛ ɔtaa twa n'ani bshwɛ fi.

Da bi na anomaa bi besii Abena dan so hyɛ ase too dwom sɛ “Abena oni awu, ɔse awu, ɔntee. Etu reto pompom, m me a resu yɔɔ. Abena oni awu, ɔse awu, ɔnte”.

Abena ante anomaa no nnwom no ase enti ɔkɔfrɛ Adanko sɛ ɔmmɛkyerɛ no ase. Anomaa no too dwom no maa Adanko kyerɛ ase sɛ, Abena, wo maame ne wo papa aka baabi. Ɛho ara na Abena tuce ne ti sui.

Saab ere yi, na Abena nkɔɔ ne nkyi da; onnim nea akɔ so biara. Ɛho ara na Abena boa ne ho kɔɔ ne kurow.

Ampa, Abena duruu fie no, na n'awofo no awu a, wante amma ayi. Osui pa ara.
NSEMMISA:

12. Asem titire ben na ayɛsem yi da no adi?

- A. Batadie ye
- B. Batadie nye
- C. Nkae fie
- D. Tu bata

13. Anansesem mma sen na wohu wɔ ayɛsem yi?

- A. Biako
- B. Abien
- C. Anan
- D. Abiessa

14. Kyerɛw ntohohosɛm biako firi ayɛsem yi mu.

- A. Ɔse awu ɔntee
- B. Ousi pa ara
- C. Ɔnnyɛ n'ade te sɛ ɔmani
- D. Efie ne fie

15. “Anomaa bi besii Abena dan so hyɛ ase too dwom” yɛ kasasu ben?

- A. Ɛbɛ
- B. Kasakoa
- C. Nnyinahɔma
- D. Sɛɔnipa

PAPER 2
PART I
COMPOSITION
30 MARKS

Yi nea edidi so yi mu biako pɛ na fa nsemfua beyɛ ɛfɛ kyere ho asem.

- ɛ. Wonyaa adamfo bi berɛ a wo sukuu ne sukuu afoforo kɔsii akan. Kyerɛw krataa kɔma w'adamfo no na kyere no sɛnea w'ani si gyee akansie no ho.
- d. Kyere sɛnea wosi noa aduan a wopɛ pa ara
- u. Memenda anɔpa biara wunni adagye. Kyerɛw nea woyɛ no Memenda anɔpa biara.
- ɔ. Ghana na wopɛ sɛ wobɛtena anaa Aburokyire?

PART II
COMPREHENSION
10 MARKS

Kenkan nea edi so yin a bua nsemmisa no nyimaa.

Mmere bi papa bi ne ne yere tenaa akuraa bi a wɔfrɛ no Domeabra. Wɔwoo mmammea baanu, Afrakuma ne Boatemaa.

Wɔn agya wui na wɔyɛ mmofra. Wɔn papa mui afe akyi no wɔn maame nso wui.

Mmom, ansa na wɔn maame rebewu no, ɔfrɛ Afrakoma baa ne nkyɛn na ɔkaa sɛ “Meyare pa ara, na mesuro sɛ, ebia merentumi nyina ano, ɛno nti mede Boatemaa hyɛ wo nsa. Hwɛ ne so yi ye. Sɛ onyin a, pɛ ɔbarima papa a ɔbeyɛ ne hokafo. Sɛ ɔwo mma a, hwɛ ɔne ne mma ni yiye. Yɛ ne mma no te sɛ w'ankasa wo yam mma, na tete wɔn yiye. Fa nea mewɔ ne nea mede ama wo nyinaa hwɛ wɔn.

Afrakuma hyɛ bɔ sɛ obedi nea waka akyere no so. ɛnam bɔhyɛ a ɔde ahyɛ ne maame nti, ɔhwɛɛ ne nuabea no yiye kɔsii bere a na wɔrehyɛ wɔn fa. Afrakuma de ne sika kɔkɔ kɔnmuaɛ maa Boatemaa sɛ ɔmfa nni afahyɛ no. Ne tiri anyɛ yiye, kɔnmuaɛ no yerae.

Nsɛmmisa :

- a. Na awarefo no mma yɛ ahe?
- b. Bere bɛn na mmofra no awofo wui?
- c. “Ebia, merentumi nyina ano” kyɛrɛ sɛn?
- d. Kyɛrɛw kasakoa biako firi ayɛsɛm yi mu.
- e. Wodwen sɛ adɛn nti na maame no de Boatemaa hyɛ Afrakuma nsa sɛ onhwɛ no?
- f. Kasasu bɛn ni? “Pɛ ɔbarima papa a ɔbɛyɛ ne hokafo”
- g. Adɛn nti na Afrakluma de kɔnmuade no maa Boatemaa?
- h. Okwan bɛn so na kɔnmuade no faa so yerae?
- i. Wugye di sɛ ayɔnkofa bɛn na sɛɔda nuanom yin tam wɔ kɔnmuade no year akyi?
- j. Fa nsɛmfua a ɛmmoro ason to ayɛsɛn yi din.

PART III

TRANSLATION

Kyɛrɛw kasamu a edidi so yi kɔ Akuapem Twi mu

- a. The students were rewarded for their performance.
- b. I saw a snake in the bush on my way to school.
- c. It rained heavily this morning.
- d. The teacher is very thirsty.
- e. The harmattan is very severe this year.
- f. Who came here yesterday?
- g. You must be careful on the road.
- h. Kofi ate all the food on the table.
- i. The big black cat jumped over the wall.
- j. Why do people cheat others so much in this country?

PART IV
LANGUAGE AND USAGE
10 MARKS

Kyerɛw nsemfuakuw a wɔasensan ase no biara din.

- a. Obea yi ho yɛ fɛ yiye.
- b. Obarima no ne ne yere tuu kwan nnera.

Fa nsem a ɛfata wie kasamu a edidi so yi:

- c. Kasamu a ekura Addeyɔ biako pɛ na yɛfrɛ no.....
- d. Kasamu kuntann wɔ kasamufa titire biako ne.....kasamufa.

Yiyi nsemmisa yi ano

- e. Kasamu bɛn ni? “Wankɔ sukuu efisɛ ɔyare”.
- f. Kyerɛw kasamu kuntann ho nhwɛso biako.

Fa akyerɛw mu agyinahyɛde toto kasamu yi ho naenwie peyɛ

- g. Oɔɔ batersɛ ntoosi ne ntɔrewa
- h. Woadi aduan bu anɔpa yi

Kyerɛw nsemfua a edidi so yi yi ye

- i. Gyniae
- j. Mbapao

TWI (ASANTE)
PAPER 1 – OBJECTIVES
Bua nsemmissa no nyinaa
Customs and Institutions

1. Wɔwoo Sɛɛwaa Benada. Sɛɛwaa Kradin beɣe.....
 - A. Akosua
 - B. Abenaa
 - C. Akua
 - D. Afua

2. Wɔde Yaw Mensa dii ne kuro so hene ɛfiri sɛ ɔɣe.....
 - A. Sikani
 - B. Kokɔdurufɔ
 - C. Ɔdehyeɛ
 - D. Nipa Kɛeɛ

3. Ansana ɔbarima bi beko akɔɣe ɔbaa bi ho adeɛ no, gye sɛ.....
 - A. Wakɔbo kɔkɔko
 - B. Ɔwɔ sika
 - C. Wanyem ɔbaa no
 - D. Watu ne ti nsa

4. Suban bɛn na yɛshu wɔ Agona abusua ho?
 - A. Aniden
 - B. Akokɔduro
 - C. Ayamye
 - D. Anoteɛ

LISTENING AND SPEAKING

5. Deɛ ɛdidi soɔ yi mu baako de nsonsonoeɛ ba snɛmfua ntam
 - A. ɛnne
 - B. Kasa
 - C. Adesua
 - D. Nwom

6. ɛnne mmuenu a ɛwɔ aɛmfua papa father mu yɛ ɛsoro anaa ɛfam
 - A. ɛfam
 - B. ɛsoro ne fam
 - C. ɛsoro
 - D. ɛfam ne soro

7. Nsɛnsini dodoɔ sɛn na ɛwɔ aɛm “akoko” mu?
 - A. Nnan
 - B. Mmiɛnsa
 - C. Num
 - D. Nsia

ORAL LITERATURE

8. Edin bɛn na wɔde ma abɔsɛɛ ahodoɔ a wɔn din pue anansɛsɛm mu?
 - A. Kwaku Ananse
 - B. Nyankonsɛm
 - C. Abɔdɛɛ pa
 - D. Anansɛsɛm mma

9. Abuasuapanin atia ne nan akyi. Yei kyɛrɛ sɛ
 - A. Oyare
 - B. Watu kwan
 - C. Wapira
 - D. Wayera

10. “Kofi deɛ ɔmpɛ su....” Deɛbɛn mu na woobɛhunu saa aɛm yi?
 - A. Nsaguo
 - B. Awareɛ
 - C. Mmagyegyedwom
 - D. Anansɛsɛm

11. Mpanin se “ɔkɔtɔ now anoma”. Saa bɛ yi ase kyere sɛ
- A. Ntɔkwa nyɛ
 - B. Ehuro nyɛ
 - C. Ɔkɔtɔ kyiri anomaa
 - D. Ɖba sɛ oni

WRITTEN LITERATURE

Kenkan deɛ ɛdi soɔ yi na bua ɛho nsemmissa no.

Ɖbɔfoɔ bi tenaa ase wɔ Kwaeɛ bi ano. Bere biara na ɔkɔ kwaeɛ no mu kɔkum mmoa. Awerɛhosɛm ne sɛ na ɔnnim aboa yarefoɔ. Sɛ ɔnya nam no nso a, ɔwe no te sɛ deɛ ɔrenom nuso. Ɖno nko ara tumi we ɔtwe mua a ɔmma obiara.

Da koro bi a ɔkɔɔ wuram no, ɔkɔhunuu kusie bi a fidie atwa ne nan. Ɖyɛɛ sɛ ɔreto no tuo no, kusie no bisaa no sɛ adɛn mmoa akeseɛ a ɔku wɔn no nso no anaa. Ɖbɔfoɔ yi ho dwirii no ma ɔtwa hwee fam wuuie.

12. Kyere asɛntitire a akenkansɛm yi da no adi
- A. Ahayɔ nyɛ
 - B. Atirimuɔ den nyɛ
 - C. Namweɛ pii nyɛ
13. Kasasu bɛn na ɛwɔ “ɔwe no te sɛ deɛ renom nsuo” mu.
- A. Sɛnipa
 - B. Ntimu
 - C. Asesɛsɛm
 - D. Nnyinahɔ
14. Hwan na akenkansɛm yi ka ne ho asɛm?
- A. Kusie
 - B. ɔtwe
 - C. Kwaeɛ
 - D. Ɖbɔfoɔ
15. Kusie no bisaa no sɛ.....kasasu bɛn na ɛwɔ saa asɛm yi mu?
- A. Sɛnipa
 - B. Ntotohosɛm
 - C. Nnyinahɔma
 - D. Ɖbɛ

PAPER 2**PART I – COMPOSITION – (30 MARKS)**

1. Fa nsemfua beye zha aduonum twere des edidi soɔ yi mu baako ho asem.
 - a. Wonyaa adamfoɔ bi bere a wo sukuu ne sukuu afoforɔ bi kɔsii akan. Twere krataa kɔma w'adamfo no na kyere no sɛdes w'ani si gyee akansie no ho.
 - b. Kyere sɛdes wɔnoa aduane a wope pa ara.
 - c. Memenda anɔpa biara wonni adaagye. Ka des woye no Memeneda anɔpa biara kyere w'ayɔnkofɔɔ.
 - d. Wope se wobstena Ghana anaa aburokyire

PART II – COMPREHENSION – (10 MARKS)

2. Kenkan des edie soɔ yi na bua nsemmissa a sfa ho no nyinaa.

Bere bi panim bi ne ne yere tenaa akuraa bi a na wɔfre no Obimma. Na wɔwɔ mma mmaa baanu a eye Afrakoma ne Boatemaa. Wɔn papa nuis na wɔsusua. Wɔn papa nuis no, afe na wɔn maame nso nuis.

Ansana wɔn maame rebɛwu no, ɔfre Afrakoma de too n'anim se “meyare pa ara na menim se merenni. Yei nti mede Boatemaa he wo nsa. Hwe no yie ma me. Se ɔnyini a pe ɔbarima papa bi ma no ne no ntena. Se ɔwo nso a, fa ne mma no se wankasa wo mma na hwe ɔne ne mma no. Fa nneɛma a mede ama wo ne des mewɔ nyinaa hwe wɔn.

Afrakoma hye ne maame bo se des waka nyinaa no, ɔbedi so. Enam Afrakoma bo a ɔhyese nti no, ɔtene ne ho hwe ne nuabaa yi kɔpem sda a na wɔrebɛdi wɔm kurow afahye. Afrakoma de ne kɔnmuaɛe a eye sika kɔkɔ maa Boatemaa se ɔmfa nye fa no nanso awerɔhosɛm ne se Boatemaa yeraa kɔnmuaɛe no.

- a. Mma sen na na awarefoɔ yi wɔ?
- b. Bere ben na mmɔfra yi hweree wɔn awofɔɔ?
- c. Kyere saa asem yi ase sɛdes steɛ wɔ akenkansɛm yi mu “merenni”.
- d. Yi kasakoa baako firi akenkansɛm yi mu.
- e. Wogyɛ di se deɛben nti na Afrakoma na maame no de Boatemaa gyaa no?
- f. Kasasu ben na sɔwɔ asem “ne no ntena” mu?
- g. Adɛn nti na Afrakoma de kɔnmuaɛe ni maa Boatema?
- h. Wogyɛ di se eye den na kɔnmuaɛe no yeraae?
- i. Sen nan a anuanom yi asetena beye bere a kɔnmuaɛe no yeraae?
- j. Fa nsemfua a emoro nson to akenkansɛm yi din

PART III – (10 MARKS)

- u. Kyere Kasamu ahodoɔ yi ase kɔ Asante Twi mu.
- The students were rewarded for their performances.
 - I saw a snake in the bush on my way to school.
 - It rained heavily this morning.
 - The teacher is very thirsty.
 - The harmattan is very severe this year.
 - Who came here yesterday?
 - You must be careful on the road.
 - Kofi ate all the food on the table.
 - The big black cat jumped over the wall.
 - Why do people cheat others so much in this country?

PART IV**LANGUAGE AND USAGE - 10 MARKS**

Kyere kasakuo a deɛ wɔasensane aseɛ no firi mu.

- Obaa yi ho ye fe yie
- Obarima no ne ne yere tuu kwan nnora

Fa nsemfua a efata wie kasamu a edidi soɔ yo

- Kasamu a ewɔ adeye baako pe na yefre no.....
- Kasamu tenten ye kasamu a ewɔ kasamufa titire baako ne.....

Bua nsemfua a ewɔ aseɛ yi

- Wankɔ sukuu efiri se na oyare kasamu ben ni?
- Ma kasamu tenten ho nhwesɔ baako

Fa atwere mu agyinahyedes twere kasamu a edidi soɔ yi yie

- Otoɔ bayerɛ, ntoosi ne nyaadewa
- Woadi aduane bi anɔpa yi

Twere nsemfua a edidi soɔ yi yie

- Gnaiyse
- Pbmaao

MATHEMATICS

STRUCTURE AND SCHEME OF THE EXAMINATION

The examination will consist of **two** papers: Paper 1 will be Objective Test and Paper 2 will be Essay.

1. PAPER 1 (OBJECTIVE)

This will consist of 40 compulsory objective questions and will last for 1 hour. This will carry 40 marks.

2. PAPER 2 (ESSAY)

This will consist of six questions and candidates are expected to answer four out of the six questions. The Paper will last 1 hour and will carry 60 marks.

3. WEIGHTING OF THE EXAMINATION

| Paper | Marks | Scaling factor | Total marks |
|---------------|-------|----------------|-------------|
| 1 (Objective) | 40 | 1 | 100 |
| 2 (Essay) | 60 | 1 | |

SAMPLE QUESTIONS**PAPER 1 (OBJECTIVE)**

- Write 2,748,595 correct to the nearest 10,000.
 - 2,700,000
 - 2,740,000
 - 2,750,000
 - 2,800,000
- Find the product of 0.0409 and 0.0021, leaving the answer in standard form.
 - 8.589×10^{-6}
 - 8.589×10^{-5}
 - 8.589×10^4
 - 8.589×10^5
- A student spent $\frac{1}{4}$ of her money on books and $\frac{1}{3}$ on transport. What fraction of the money was left?
 - $\frac{7}{12}$
 - $\frac{5}{12}$
 - $\frac{6}{7}$
 - $\frac{5}{7}$

Given that $P = \{b, d, e, f\}$ and $Q = \{a, e, f, g\}$ are subsets of the universal set $\mu = \{a, b, c, d, e, f, g\}$.

- Find $P \cup Q$.
 - $\{e, f\}$
 - $\{a, b, d, e, f, g\}$
 - $\{a, b, g\}$
 - $\{a, b, d, g\}$
- Convert $3\frac{1}{5}$ to a decimal fraction.
 - 3.7
 - 3.6
 - 3.3
 - 3.2

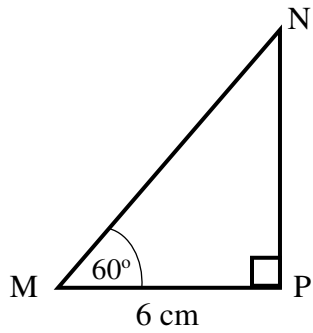

Not Drawn to Scale

In the diagram, $\angle PMN = 60^\circ$, $|MP| = 6 \text{ cm}$.
 [Take $\tan 60^\circ = \sqrt{3}$]

6. Find the length of $|NP|$.
- A. $6\sqrt{3}$
 - B. $3\sqrt{6}$
 - C. $2\sqrt{6}$
 - D. $2\sqrt{3}$
7. Simplify: $\sqrt{2} + \sqrt{3} + \sqrt{8} + \sqrt{27}$
- A. $3\sqrt{2} + 4\sqrt{3}$
 - B. $4\sqrt{2} + 3\sqrt{3}$
 - C. $2\sqrt{2} + 3\sqrt{3}$
 - D. $3\sqrt{2} + 2\sqrt{3}$

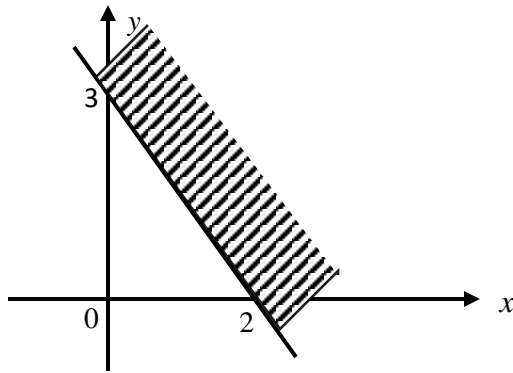

8. Which of the following inequalities represents the shaded region in the diagram?
- A. $3x + 2y \geq 6$
 - B. $3x + 2y \leq 6$
 - C. $2x + 3y \geq 6$
 - D. $2x + 3y \leq 6$
9. Given that vector $\mathbf{m} = \begin{pmatrix} 3 \\ -1 \end{pmatrix}$ and $\mathbf{n} = \begin{pmatrix} -4 \\ 1 \end{pmatrix}$, evaluate $2\mathbf{m} - \mathbf{n}$.
- A. $\begin{pmatrix} 10 \\ 3 \end{pmatrix}$
 - B. $\begin{pmatrix} 10 \\ -3 \end{pmatrix}$
 - C. $\begin{pmatrix} -10 \\ 3 \end{pmatrix}$
 - D. $\begin{pmatrix} -10 \\ -3 \end{pmatrix}$
10. A fair die and a fair coin are rolled together **once**. Find the probability of obtaining a head and an even number.
- A. $\frac{1}{4}$
 - B. $\frac{1}{3}$
 - C. $\frac{1}{2}$
 - D. $\frac{2}{3}$

PAPER 2 (ESSAY)Answer **four** questions **only**.*All questions carry equal marks*

1. (a) Simplify: $7\frac{1}{2} - (2\frac{1}{2} + 3) \div \frac{33}{2}$
- (b) Philip and Emelia shared a number of oranges in the ratio 3: 5. If Emelia received 20 more oranges than Philip, find the total number of oranges they shared.
- [15 marks]**
2. Awo shared 80 acres of land among her 3 children. She gave 5 acres to the first child for taking care of the land and shared the rest of the land equally among the three children.
- (a) How many acres of land did the first child have?
- (b) What percentage of the land did the other children have?
- [15 marks]**
3. A fair coin is tossed **twice**.
- (a) List all the possible elements in the sample space.
- (b) Find the probability of obtaining:
- (i) a head and a tail;
- (ii) exactly two tails;
- (iii) no tail;
- (iv) at **least one** tail.
- [15 marks]**
4. (a) Solve: $\frac{3}{4}h + \frac{1}{3}(21 - h) = 12$
- In the diagram, PQ is parallel to SN and UT is a transversal. Angle $QMT = 55^\circ$ and $\angle SRT = (y + 10)^\circ$.

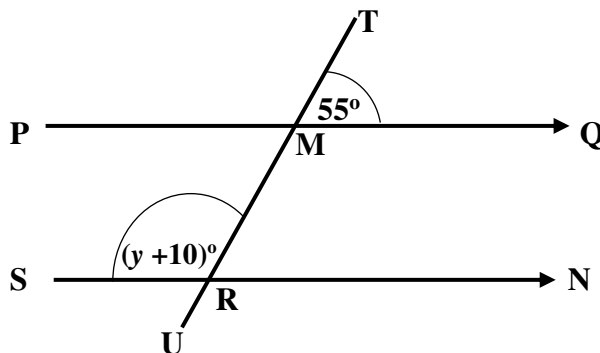
**Not Drawn to Scale**

- (b) Find the value of y .

[15 marks]

5. The data shows the marks obtained by 10 students in a test.

7, 6, 10, 8, 4, 5, 7, 12, 6, 5

Find the:

- (a) range;
- (b) median;
- (c) mean.

[15 marks]

6. A ladder leaned against a school building at a point P from the same horizontal ground.

The angle of elevation from the foot of the ladder to P is 60° and the distance from the foot of the ladder to the base of the building is 3m.

[Take $\cos 60^\circ = \frac{1}{2}$ and $\tan 60^\circ = \sqrt{3}$]

- (a) Illustrate the information in a diagram;
- (b) Find the
 - (i) length of the ladder;
 - (ii) height of the building at point P .

[15 marks]

RELIGIOUS AND MORAL EDUCATION

STRUCTURE AND SCHEME OF THE EXAMINATION

There will be two papers: Paper 1 and Paper 2. The two papers will be a composite paper to be taken together.

1. PAPER 1 (OBJECTIVE)

The paper will be a multiple-choice objective paper made up of 40 questions drawn from the entire syllabus. All the questions must be answered in 45 minutes for 40 marks.

2. PAPER 2 (ESSAY)

The paper will be made of two sections; **Section A and B** to be answered in 1 hour. **Section A** will be a compulsory question and **Section B** will have four questions from which candidate will be expected to answer two. Candidates are expected to answer three questions in all for a total of 60 marks.

3. WEIGHTING OF THE PAPER

| PAPER | MARK | SCALING FACTOR | TOTAL |
|---------------|------|-------------------|-------|
| 1 (Objective) | 40 | 1 | 100 |
| 2 (Essay) | 60 | 1 | |

SAMPLE QUESTIONS**PAPER 1 (OBJECTIVES)****SAMPLE QUESTIONS****OBJECTIVES**

1. Which of the following is the final stage of the process of repentance?
 - A. A request for doing wrong
 - B. Promise not to repeat same bad deed
 - C. Request for pardon
 - D. Acceptance of one's fault

2. Which of the following is an important factors to consider when greeting someone?
 - A. The number of children one has.
 - B. The tribe of the person.
 - C. The attire of the person.
 - D. Time of the day.

3. The proverb "patience moves mountains" highlights the importance of
 - A. education.
 - B. perseverance.
 - C. faithfulness.
 - D. diligence.

4. The most significant sign of puberty that makes girls certainly ready for childbirth is
 - A. development of the breast.
 - B. development of hips.
 - C. growth of pubic hairs.
 - D. onset of menstruation.

5. The Ten Commandments in Christianity highlight the teaching on
 - A. love.
 - B. faithfulness.
 - C. justice.
 - D. obedience.

6. Which of the following human activities destroys the environment?
 - A. Tree planting
 - B. illegal mining
 - C. afforestation
 - D. mixed farming

7. According to Islamic creation story, the third step in the creation of humankind is
 - A. a baby
 - B. clot of blood
 - C. dust
 - D. sperm drop

8. Which of the following is the major role of a Caliph in Islam? To
 - A. succeed prophet Mohammed.
 - B. compile the Quran into one volume.
 - C. read out the Quran.
 - D. travel from Makkah to Medina.

9. In order to maintain a united and progressive family, which of the following must be adhered to?
 - A. Only parents must play their roles
 - B. Only children must play their roles
 - C. All members must play their roles
 - D. Parents and grandparents must play their roles

10. The proverb, "Good name is better than riches" implies that
 - A. one's name identifies him or her.
 - B. we must make money at all costs.
 - C. money answers all things.
 - D. reputation is worth more than riches.

ESSAY (PAPER 2)**SECTION A- COMPULSORY**

1. Mensah and his friends were tasked by their class teacher to form groups of 7 membership for a project work. The project work was supposed to target environmental problems around the school premises and find solutions to them. Mensah and his group decided that they would plant more trees at vantage places around the school as their project work.
- (a) Identify which environmental problem Mensah and his group intend solving
(2 marks)
- (b) State **two** other environmental problems other member of the other groups can look at.
(4 marks)
- (c) Explain **four** human activities that destroys the environment
(8 marks)
- (d) Outline **two** reasons for which it is important to care for the environment.
(6marks)

SECTION B (Answer any two questions from this section)

2. Emma, in a friendly chat with Daniel said growing up, he had always wish to be an only child living with only his dad and mum just like him. He further went on to say that sometimes it was a little crowded around the house with seven brothers and sisters. What actually worries Emma was the fact that they also have his grandparent, uncles, aunties and cousins on the same compound yet everyone thinks it is the duty of the person to perform certain roles and at the ends nobody does anything. He is really not a happy person.
- (a) What type of family system does Emma belongs to?
(2 marks)
- (b) State **two** benefits Daniel would enjoy in his family over Emma.
(4 marks)
- (c) Explain **three** advantages of Emma's family system
(6 marks)
- (d) Explain **four** reasons for which all members of a family must perform their roles effectively.
(8 marks)

3. (a) Highlight **four** ways by which a student can profitably use his/her leisure time. **(12 marks)**
- (b) Identify **four** importance of leisure to the student. **(8 marks)**
4. Rashid and Fati are planning on getting married by Islamic customs. They have done everything a would-be couple would do to have a successful ceremony. They have contacted all the people they needed to so that the day of the ceremony would be memorable. During one of their visit, they met an elderly women who advised them that it is good to have a wonderful ceremony but it will be more memorable if they think of marriage beyond the ceremony.
- (a) State **two** differences between Islamic marriage and Christian marriage. **(4 marks)**
- (b) Explain **four** conditions necessary for an Islamic marriage. **(8 marks)**
- (c) Outline four ways of sustaining marriages. **(8 marks)**

SCIENCE

STRUCTURE AND SCHEME OF THE EXAMINATION

There will be two papers: Paper 1 and Paper 2 both of which must be taken. The two papers will be a composite paper to be taken at a sitting.

1. PAPER 1 (OBJECTIVE)

This will be objective paper made up of **40 questions** drawn from the entire syllabus. All the questions must be answered in **45 minutes**.

2. PAPER 2 (ESSAY)

This shall be an essay paper made of 2 sections. Section A and B to be answered in **1 hour 25 minutes**.

Section A: will be one compulsory question consisting of four sub questions testing in practical skills specified in Agriculture, Biology, Chemistry and Physics aspects of the examination syllabus. This will attract **40 marks**.

Section B: will consist of four questions. Each question shall be a blend of Agriculture, Biology, Chemistry and Physics aspects of the examination syllabus. Candidates will be required to answer any three of the question for **60 marks**.

3. WEIGHTING OF THE PAPER

| Paper | Items | Scaling factor | Total marks |
|------------------|--------------|-----------------------|--------------------|
| 1 (Objective) | 40 | 1.0 | 100 |
| 2 (Essay) | 4 | 0.6 | |

SAMPLE QUESTIONS**PAPER 1 (OBJECTIVES)**

1. The series of changes that occur during the development of a housefly is called
 - A. growth.
 - B. cycle.
 - C. reparation
 - D. metamorphosis

2. Compost is not an ideal choice for use as mulch because
 - A. It is unsanitary
 - B. it attracts squirrels, ants and other critters looking for food.
 - C. the nutrients are too concentrated and will kill the plants.
 - D. the nitrogen evaporates into the air instead of the soil.

3. In which part of the monogastric digestive system does microbial digestion takes place?
 - A. Large intestine
 - B. Rectum
 - C. Caecum
 - D. Oesophagus

4. Which of the following best describes why carbon cycle is said to be a repeated pattern in nature? (U)
 - A. It helps to maintain a balanced level of CO₂ in the earth's atmosphere.
 - B. It makes carbon dioxide available for plants to use for photosynthesis.
 - C. It involves carbon-sequestration process.
 - D. There is a continual exchange of carbon between the earth and the atmosphere

5. The **main** reason why hay making is less common in tropical Africa especially Ghana is because
 - A. the animals can forage all year round.
 - B. pastures contain abundant forage all year round.
 - C. grazing animals are only reared for ritual purposes.
 - D. grazing animals are reared under the intensive system

6. The grasshopper life cycle is said to be incomplete metamorphosis because the grasshopper
 - A. has both a caterpillar and nymph in its life cycle.
 - B. life cycle has five stages.
 - C. life cycle has two very different stages.
 - D. life cycle has only 3 stages; adult, nymph, and egg

7. A feeding relationship consists of different organisms including maize, dog and lion. Which trophic level is missing in the feeding relationship?
 - A. Primary consumer
 - B. Dominant producer
 - C. Secondary consumer
 - D. Tertiary consumer

8. The system of farming that is **most** likely to ensure harvest different types of crops at the end of the season is
 - A. mono-cropping
 - B. mixed farming
 - C. mixed cropping
 - D. irrigational farming

9. A patient who reports to the hospital with a gum related disease is most likely suffering from
 - A. periodontal disease
 - B. gingivitis
 - C. dental caries
 - D. gummosis

10. The part of the digestive system that **does not** contain digestive enzymes is the
 - A. duodenum
 - B. mouth
 - C. oesophagus
 - D. stomach

ESSAY

1. (a) State two conditions that makes the presence of life on Jupiter difficult. **(2 marks)**
- (b) Explain **two** steps involved in the preparation of manure. **(2 marks)**
- (c) State **two** diseases that affect the circulatory system of humans **(2 marks)**
- (d) Explain briefly why a community will not be encouraged to practice mixed cropping. **(3 marks)**
- (e) Briefly describe a test you will conduct to prove the presence of proteins in a piece of meat. (A) **(5 marks)**
- (f) Explain the term respiration (U) **(2 marks)**
- (g) Identify **three** human activities that are destroying the balance of ecosystems in Ghana. **(3 marks)**

2. (a) Distinguish between land rotation and crop rotation (U) **(2 marks)**
- (b) Explain what happens to a morsel of kenkey as it travels along the alimentary canal (A) **(4 marks)**
- (c) (i) Name **three** parts of the human circulatory system.
(i) Give **one** function of each part of the parts named in (i). **(6 marks) (K)**
- (d) Distinguish between an inner planet and an outer planet. (U) **(2 marks)**
- (e) Consider three different animals namely, lion, sparrow and tilapia
(i) Identify the type of ecosystem that each of these organisms live in (U)
(ii) Write down one feature/adaptation that enables each of the organisms to live successfully in the ecosystem in (i) above. (A) **(6 marks)**

TEST OF PRACTICALS

1. The diagram below shows various ways in which Nitrogen is cycled in nature, study it carefully and answer the question that follows;

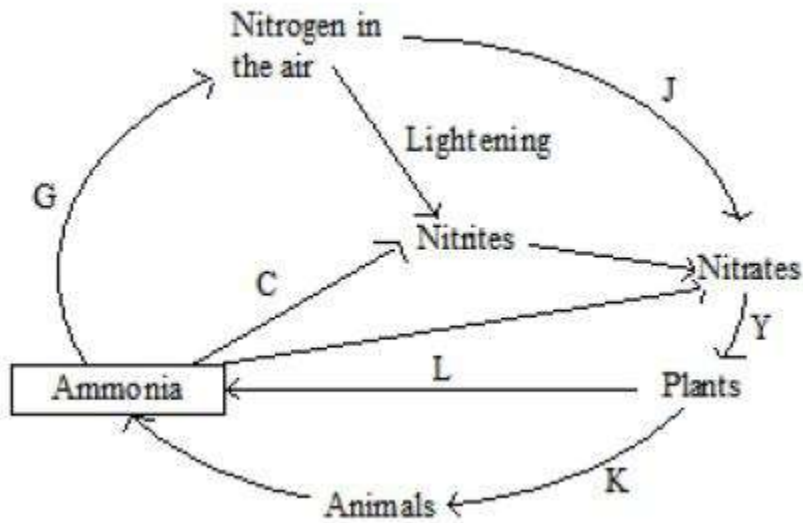

- Identify the stages **labelled** C, G, J, K, L and Y
- Describe the processes labelled G and Y
- Explain how certain plants fix nitrogen in the soil
- State two importance of the cycle to the environment.

[6 Marks]

[4 Marks]

[2 Marks]

[2 Marks]

2. The picture below shows parts of the solar system. Study it carefully and use it to answer the questions that follow

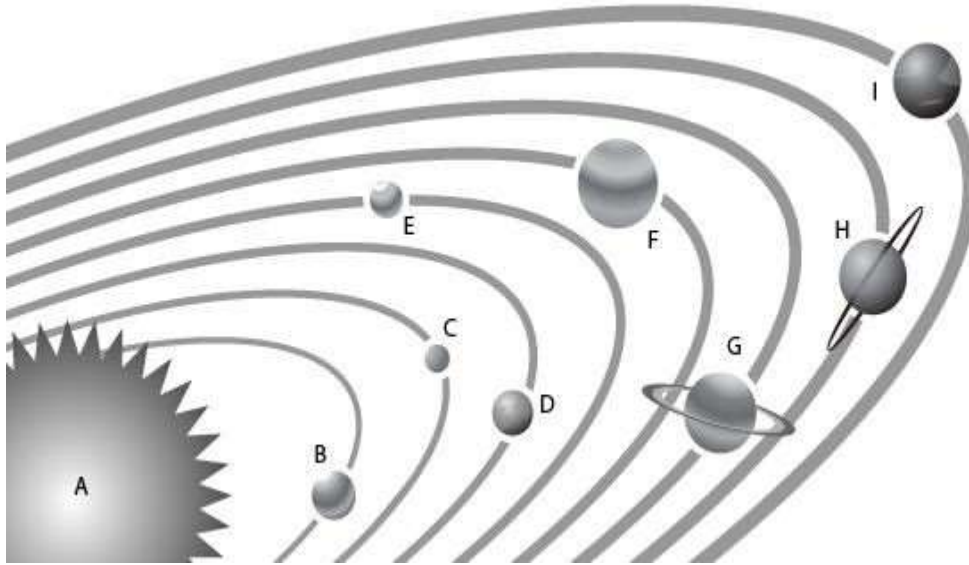

- Name the parts labelled A, B, C, D, E, F, G, H, and I
- Which of the parts named is known as the twin of the earth?
- Group the objects A, B, C, D, E, F, G, H, and I into inner planet and outer planet.
- Which of the labelled parts supports life?
- Give **two** reasons why the part named in (d) supports life.
- Give one difference between the parts labelled B and A

SOCIAL STUDIES

STRUCTURE AND SCHEME OF THE EXAMINATION

The examination will consist of two papers – Paper 1 (Objective) and Paper 2 (Essay).

1. PAPER 1 (OBJECTIVE)

This will consist of 40 objective questions of 45 minutes duration and a total score of 40 marks.

2. PAPER 2 (ESSAY)

This will be a **1 hour** essay-type paper consisting of three sections I, II and III. One compulsory question will be set for Section I and two questions will be set for Sections II and III respectively. Candidates are expected to answer one question each from sections II and III.

The Sections are:

I: The Environment

II: Law, Order and Nation Building

III: Social and Economic Development

Candidates will be expected to answer **three** questions in all out of five (5) questions. Answering one compulsory question and any other in section I and one question each from sections II and III.

3. WEIGHTING OF THE PAPER

| PAPER | MARKS | SCALING FACTOR | DURATION | TOTAL MARKS |
|---------------|-------|----------------|----------|-------------|
| 1 (Objective) | 40 | 1 | 45 min | 100 |
| 2 (Essay) | 60 | 1 | 1 hr | |

SAMPLE QUESTIONS**PAPER 1 (OBJECTIVE)**

1. The component of a map that enables one to identify the distribution of features is referred to as
 - A. scale.
 - B. legend.
 - C. conventional signs.
 - D. cardinal points.

2. Socialisation is important for the development of society as it
 - A. encourages rural-urban migration.
 - B. gives respect to the rich in society.
 - C. fosters social cohesion.
 - D. makes one popular.

3. Aggressive behaviour of an adolescent is
 - A. a social characteristics.
 - B. an emotional characteristics.
 - C. physical characteristics.
 - D. cognitive characteristics.

4. The cornerstone of a democratic system of government is the rule by the
 - A. prime minister.
 - B. legislature.
 - C. president.
 - D. people.

5. One of the causes of environmental pollution in Ghana is
 - A. inadequate sanitary inspection.
 - B. absence of recycling plants.
 - C. inadequate waste management practices.
 - D. absence of global control measures.

6. The area people live and work is termed as
 - A. social environment.
 - B. physical environment.
 - C. cultural environment.
 - D. economic environment.

7. The Act in Ghana which aims to bring certainty and fairness to the distribution of property of a person who dies without a will is termed
 - A. widowhood rite law.
 - B. intestate succession law.
 - C. testate law.
 - D. equity law.

8. The right of a citizen to open and fair trial falls under
 - A. legal rights.
 - B. natural rights.
 - C. economic rights.
 - D. social rights.

9. Your class is organizing a treasure hunt in a community in Ghana. What would be the most essential activity that will make the trip successful?
 - A. Designing a map with clear landmarks and directions.
 - B. Writing a letter to seek permission from school authorities.
 - C. Seeking permission from parents.
 - D. Providing lunch pack.

10. The individual's self-confidence and values can be promoted through
 - A. loving oneself.
 - B. hardwork.
 - C. setting goals.
 - D. risk taking.

PAPER 2 (ESSAY)

All Candidates are expected to answer question 1(compulsory) in Section 1
Candidates are to answer 1 question each from sections II and III

SECTION I

1.(a) Ghana has a vast stretch of fertile land, however many of the people do not have enough food to eat. In your opinion, what **four** factors have you identified as the cause of the problem?

[12 marks]

(b) In what **four** ways can the problems raised in (a) above be solved through the use of science and technology?

[8 marks]

SECTION II

2.(a) With examples differentiate between the agents of socialisation and the agencies of socialisation to a friend.

[8 marks]

(b) Which **three** bodies have guided you to know the values and cultural practices of your community?

[12 marks]

3.(a)(i) What is your understanding of a map?

[4 marks]

(ii) Give an example of a type of a map.

[2 mark]

(b) Your teacher has asked you to draw a map of your school.

(i) State the **four** tools you will need to carry out this assignment.

[4 marks]

(ii) Describe the steps you will follow to accomplish this task

[10 marks]

SECTION III

4. (a) As an individual, in what **four** ways can you contribute to the development of your community?

[8 marks]

(b) In your view, state **three** factors you will consider in the community decision-making process.

[12 marks]

5. (a) How do you understand marriage as a social institution?

[5 marks]

(b) Highlight **five** reasons marriages break down in your community.

[15 marks]

ADDRESSES OF OFFICES OF THE COUNCIL IN GHANA

Head Office

The West African Examinations Council
Examination Loop (Behind Ridge Hospital)
P. O. Box GP 917, Accra.
Tel: (233-302)-208201-9
Fax: (233-302)-208200
Email: info@waecgh.org
GPS Address: GA-028-4961

Sunyani Branch Office

The West African Examinations Council
Behind Ghana Legion & District Assembly
Offices
P. O. Box 190, Sunyani, Brong Ahafo Region.
Tel: 0352-024462/27016
GPS Address: BS-0022-8262

Kumasi Branch Office

The West African Examinations Council
Near Kumasi Technical Institute (KTI)
P. O. Box 3515, Kumasi, Ashanti Region.
Tel: 0322-034452/26064/34453/34449
GPS Address: AK-021-2220

Ho Branch Office

The West African Examinations Council
Opposite Roads and Highways Offices
P. O. Box 455, Ho, Volta Region.
Tel: 0362-026164/28254
GPS Address: VH-0004-6862

Koforidua Branch Office

The West African Examinations Council
Old Estate Road, Nsukwao
P. O. Box KF6, Koforidua, Eastern Region.
Tel: 0342-020075/20921/20922
GPS Address: EN-004-7100

Tamale Branch Office

The West African Examinations Council
(Near GNAT Hostel)
P. O. Box 155 ER, Tamale, Northern Region.
Tel: 0372-022854/23092
GPS Address: NS-046-2300

Cape Coast Branch Office

The West African Examinations Council
Mempeasem, Off Jukwa Road
P. O. Box 828, Cape Coast, Central Region.
Tel: 0332-032878/37086/37085
GPS Address: CC-260-5684

Bolgatanga Branch Office

The West African Examinations Council
SOE Residential Area
(Near Catering Rest House)
P. O. Box 327, Bolgatanga, Upper East Region.
Tel: 0382-024267/23232
GPS Address: UB-0092-1763

Sekondi Branch Office

The West African Examinations Council
Adjacent the Sekondi Anglican Cathedral
P. O. Box 84, Takoradi, Western Region.
Tel: 0312-046334/46041
GPS Address: WS-001-6065

Wa Branch Office

The West African Examinations Council
Chako, Behind Dept. of Feeder Roads
P. O. Box 300, Wa, Upper West Region.
Tel: 0392-022278/20588
GPS Address: XW-0258-0813